

V-TAC

Meaningful Innovation.

CATALOGUE

SOLAR ENERGY | Q1-2026

COMPLETE ENERGY SOLUTIONS FOR A BETTER TOMORROW



GLOBAL YET LOCAL

V-TAC
Meaningful Innovation.

V-TAC was founded with the vision of providing energy-efficient LED lighting solutions worldwide.

While building a vast portfolio in LED lighting over the past years, we were also able to build expertise in innovation and expand our R&D team to offer a diversified catalogue with over 5000 products to our clients and partners all over the UK and Europe.

Utilizing our brand value and manufacturing technologies, we have been expanding our product categories beyond lighting, with one mission to improve the lives of humanity worldwide.

Now, we are moving towards promoting sustainable practices that will help citizens and businesses lower their carbon footprint, and become a global leader in providing energy efficient systems — including solar panels, inverters, battery packs, and power stations.



LED LIGHTING



LIGHTING | DIGITAL
AUDIO | ELECTRICAL

[scan to view online catalogue](#)

SOLAR ENERGY



INVERTERS | BATTERIES
PANELS | ALL IN ONE ESS

[scan to view online catalogue](#)

OUR JOURNEY SO FAR

V-TAC

Meaningful Innovation.

V-TAC was founded with the vision of providing energy-efficient LED lighting solutions worldwide



2009

2011



Began our EU expansion by opening the first V-TAC warehouse and office in Sofia, Bulgaria

Started building our distribution network in the UK from our office in Southall, London.



2013

2015



Launched our in-house product testing lab in Sofia, Bulgaria.

Achieved \$100M Annual Turnover- Manufacturing Joint Venture with DASHER Lighting for decorative lighting.



2016

Centralized warehouse in Bulgaria extended to 42000+ sq mts.



2021

2020



- New website launch
- Opened new office in Ireland.

Opened new office in Poland.



2019

2018



- Partnership with Tuya and launched new Smart Series
- Unveiled the new V-TAC Showroom in Slough, UK

In-brand partnership with Samsung. Launched the V-TAC Pro series.



2017

Progressed into the green energy era with our new Renewables range



2022

2023



10 year anniversary in the UK

Announced partnerships with Midea and Sinexcel



2024

2025



In-brand partnership with CREE



ESTABLISHED
2009



PRESENCE IN
75 COUNTRIES



TURNOVER
\$150M



WHY CHOOSE V-TAC FOR SOLAR ENERGY SOLUTIONS?



At V-TAC, we pride ourselves on being a global leader in the solar energy sector, offering innovative, efficient, and sustainable products that cater to all your solar needs. Here's why V-TAC is your ideal partner in solar energy:

INNOVATION AT THE FOREFRONT

We are at the cutting edge of solar technology, thanks to our strategic partnerships with industry giants like Sinexcel, Deye, and Midea. These collaborations enable us to offer state-of-the-art solar panels, inverters, battery storage systems, and more. Our products are designed to provide superior performance and reliability, ensuring you get the most out of your solar investment.

COMPREHENSIVE RANGE OF SOLUTIONS

V-TAC is your one-stop solution for all solar energy needs. From residential to commercial applications, we offer a vast array of products including solar panels, inverters, battery storage systems, EV chargers, and complete solar kits. This extensive range ensures that you can find everything you need under one roof, simplifying the process of going solar.

UNMATCHED QUALITY AND RELIABILITY

Quality is at the heart of everything we do. Our products undergo rigorous testing in our state-of-the-art lab in Sofia, Bulgaria, and hold accreditations from top European labs. This commitment to quality ensures that every product you receive is safe, durable, and performs at the highest standards.

SUSTAINABILITY AND ENVIRONMENTAL RESPONSIBILITY

We are dedicated to promoting sustainable practices and reducing carbon footprints. Our solar products are designed to help you lower your energy costs while contributing to a greener planet. By choosing V-TAC, you are supporting a company that prioritizes environmental responsibility.

GLOBAL PRESENCE WITH LOCAL SUPPORT

With a presence in over 70 countries, V-TAC combines global expertise with local knowledge. Our extensive distribution network ensures that you receive timely support and service, no matter where you are located. We are committed to providing personalized solutions that meet your specific needs.

TABLE OF CONTENTS



Solar Inverters

06



EV Charger

58

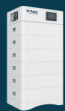

Battery Storage Solutions

60



Solar Panels

86



PV Cables

101



Solar DC String Box

102



Solar Accessories

104

SOLAR INVERTERS

V-TAC
Meaningful Innovation.



At V-TAC, our solar inverters stand out by covering all types of applications, from residential to commercial. Partnering with industry leaders like Deye, Afore, and Sinexcel, we leverage multiple innovation fronts to deliver advanced, reliable, and efficient inverters.

Our inverters are known for their high efficiency, robust performance, and smart technology integration, ensuring optimal energy conversion and ease of use. With rigorous quality control and international certifications, V-TAC inverters provide unmatched reliability and peace of mind, making them the ideal choice for any solar energy system.

Deye



Afore

invt

SINEXCEL





Single Phase On-Grid String Inverters

2kW

3kW

3.6kW

Model No:	SUN- 2K-G04P1-EU-AM1	SUN- 3K-G04P1-EU-AM1	SUN- 3.6K-G04P1-EU-AM1
SKU Code:	11956	11957	11958
Net Weight:	4.8kg	4.8kg	4.8kg
Size(MM):	280×310×184	280×310×184	280×310×184
Max. Efficiency	97.3%	97.5%	97.5%

PV INPUT DATA

Max. PV Input Power (kW)	2.6	3.9	4.7
Max. PV Input Voltage (V)	550	550	550
Start-up Voltage (V)	80	80	80
MPPT Voltage Range (V)	70-500	70-500	70-500
Rated PV Input Voltage (V)	360	360	360
Max. Operating PV Input Current (A)	20	20	20
Max. Input Short Circuit Current (A)	30	30	30
No. of MPP Trackers	1	1	1
No. of Strings per MPP Tracker	1	1	1

AC OUTPUT DATA

Rated AC Output Active Power (kW)	2	3	3.6
Max. AC Output Apparent Power (kVA)	2.2	3.3	3.96
Rated AC Output Current (A)	9.1/8.7	13.7/13.1	16.4/15.7
Max. AC Output Current (A)	10/9.6	15/14.4	18/17.3
Rated Output Voltage/Range (V)	220/230 0.85Un-1.1Un	220/230 0.85Un-1.1Un	220/230 0.85Un-1.1Un
Grid Connection Form	L/N/PE	L/N/PE	L/N/PE
Rated Output Grid Frequency/Range(Hz)	50/45-55, 60/55-65	50/45-55, 60/55-65	50/45-55, 60/55-65
Power Factor Adjustment Range	0.8 leading to 0.8 lagging	0.8 leading to 0.8 lagging	0.8 leading to 0.8 lagging
Total Current Harmonic Distortion THDi	<3%	<3%	<3%
DC Injection Current	<0.5%In	<0.5%In	<0.5%In

GENERAL DATA

Operating Temperature Range (°C)	-25 to +65, >45 Derating
Permissible Ambient Humidity	0-100%
Permissible Altitude (m)	2000m
Noise (dB)	≤35
Ingress Protection(IP) Rating	IP 65
Inverter Topology	Non-Isolated
Over Voltage Category	OVC II(DC), OVC III(AC)
Warranty	5 Years
Type of Cooling	Natural Cooling

PROTECTION & CERTIFICATIONS

Safety / EMC	IEC/EN 61000-6-1/2/3/4, IEC/EN 62109-1, IEC/EN 62109-2
Protection	DC Polarity Reverse Connection, AC Output Overcurrent, AC Output Overvoltage, Efficiency AC Output Short Circuit Thermal, DC Terminal Insulation Impedance Monitoring, DC Component Monitoring, Ground Fault Current Monitoring, Power Network Monitoring, Island Protection Monitoring, Earth Fault Detection, Overvoltage Load Drop, Residual Current (RCD) Detection, Surge Protection Level: TYPE II(DC), TYPE II(AC)
Grid Regulation	IEC 61727, IEC 62116, CEI 0-21, EN 50549, NRS 097, RD 140, UNE 217002, G98, G99, VDE-AR-N 4105



Single Phase On-Grid Inverters

ON-GRID SINGLE PHASE

5kW

6kW

SKU Code:	11979	11980
Net Weight:	10kg	10kg
Size(MM):	358x360x142	358x360x142
Max. Efficiency:	98.2%	98.2%

PV INPUT DATA

Max. DC Power (W)	7000	8400
Max. DC Voltage (V)	600	600
MPPT Voltage Range (V)	70-550	70-550
MPPT Full Power Voltage Range (V)	180-550	220-550
Rated Input Voltage (V)	360	360
Start-up Voltage (V)	70	70
Max. Input Current (A)	14 x 2	14 x 2
Max. Short Current (A)	18 x 2	18 x 2
No. of MPP Tracker / No of PV String	2/2	2/2
Input Connector Type	MC4	MC4

AC OUTPUT DATA

Max. Output Power (VA)	5500	6600
Nominal Output Power (W)	5000	6000
Max. Output Current (A)	24	28.7
Nominal Output Voltage (V)	L/N/PE, 220Vac, 230Vac, 240Vac	
Grid Voltage Range	180Vac-276Vac (According to local standard)	
Nominal Output Frequency (HZ)	50/60	
Grid Frequency Range	45-55Hz/54-66Hz (According to local standard)	
Output Power Factor	1 default (adjustable from 0.8 leading to 0.8 lagging)	
Output Current THD	<3%	

GENERAL DATA

Protection Degree	IP65
Enclosure Material	Aluminum
Ambient Temperature Range (*C)	-25 to 60
Humidity Range	0-100%
Topology	Transformerless
Communication Interface	RS485/WIFI/Wire Ethernet/GPRS(optional)
Cooling Concept	Convection
Noise Emission(db)	<28
Night Power Consumption(W)	<1
Max.Operation Altitude(m)	4000

PROTECTION & CERTIFICATIONS

Safety / EMC	IEC60068,UL1741,EN62109 - EN/IEC 61000-6-2,EN/IEC 61000-3-2,EN61000-3-3,EN61000-3-11,EN61000-3-12
Protection	PV Reverse Polarity,PV Insulation Resistance Detection, AC Short Circuit, AC Over Current, AC Over Voltage,Anti-Islanding,Residual Current Detection, Over Temperature, Integrated DC switch, Surge Protection, Smart IV Curve Scanning, Quick Arc Fault Circuit interruption:optional
Grid Regulation	IEEE1547,CSA C22,EN50549,VDE4105,VDE0126,RD1699,ABNT NBR16149&16150,AS4777.2,NB/T32004,IEC61727

Single Phase On-Grid Solar Inverter

3kW

Model No: **VT-6603105**
SKU Code: **11369**

5kW

Model No: **VT-6605105**
SKU Code: **11370**



3kW

Model No: **VT-6603110**
SKU Code: **11379**

5kW

Model No: **VT-6605110**
SKU Code: **11380**



INPUT (DC)

	3kW	5kW
Max. Input Power	3.6kW	6kW
Max. Input Voltage	600V	600V
Start Voltage / Min. Operating Voltage	120V / 100V	120V / 100V
MPPT Voltage Range	120V-550V	120V-550V
MPPT Rated Voltage	360V	360V
Number of MPP Trackers / String per MPPT	2/1	2/1
Max. Current per MPPT	9A	15A

OUTPUT (AC)

	3kW	5kW
Max. Output Current	16A	24A
Rated AC Power	3kW	5kW
Rated Grid Frequency	50Hz / 60Hz	50Hz / 60Hz
Rated Grid Voltage	230V, L+N+PE	230V, L+N+PE
Power Factor	.0.99 (Rated Power)	.0.99 (Rated Power)
THDi	<3% (Rated Power)	<3% (Rated Power)

EFFICIENCY

Max. Efficiency	97.7%	97.8%
European Efficiency	96.7%	96.8%
MPPT Efficiency	99.9%	99.9%

GENERAL DATA

Dimensions (W x H x D)	360 x 462 x 150 mm
Weight	18kg
Operating Temperature Range	-25°~+60° (Derating above 45°)
Cooling Method	Natural Cooling
Protection Degree	IP65
Noise	<30dB
Highest Altitude	3000m (Derating above 2000m)
Relative Humidity	0~95%
Topology	Transformerless
Night Power Consumption	<1W
Warranty	5years (Standard) / 10years (Optional)

PROTECTION & CERTIFICATIONS

Protection	DC switch, AC short-circuit protection, Over current protection, Over voltage protection, Isolation protection, RCD, Surge protection, Anti-islanding protection, Over-temperature protection, Ground fault monitoring, etc.
Display	LED (Optional) / LCD (Standard)
System Language	English / Chinese / German / Dutch
Communication	Standard: RS485
Grid Connection	IEC 61727:2004, IEC62116:2014, IEC 60068-2-1:2007, IEC 60068-2-2:2007, IEC 60068-2-14:2009, IEC 60068-2-30:2005, IEC 61683:1999, DIN VDE 0126-1-1:2013, DIN VDE V 0124-100:2020, VDE-AR-N 4105:2018, G98:2019, C10/11:2019, AS/NZS 4777.2:2020, NB/T 32004-2018, PEA, ZVR
Safety / EMC	IEC/EN 62109-1:2010, IEC/EN 62109-2:2011, EN 61000-6-2:2019, EN 61000-6-3:2007/A1:2011



Three Phase On-Grid Solar Inverter

5kW

8kW

10kW

Model No: VT-6605305
 SKU Code: 11371
 Net Weight: 20kg
 Size(MM): 360 x 530 x 150

Model No: VT-6608305
 SKU Code: 11372
 Net Weight: 23kg
 Size(MM): 360 x 575 x 150

Model No: VT-6610305
 SKU Code: 11373
 Net Weight: 23kg
 Size(MM): 360 x 575 x 150

INPUT (DC)

Max. Input Power	5.7kW	9kW	11kW
Max. Input Voltage	900V	1000V	1000V
Start Voltage / Min. Operating Voltage	220V / 150V	220V / 180V	220V / 180V
MPPT Voltage Range	180V ~ 800V	180V ~ 800V	180V ~ 800V
MPPT Rated Voltage	580V	610V	610V
Number of MPP Trackers / String per MPPT	2 / 1	2 / 1	2 / 1
Max. Current per MPPT	12A	12.5A	12.5A

AC OUTPUT DATA

Max. Output Current	8A	12.5A	16A
Rated AC Power	5kW	8kW	10kW
Max. Output Power	5.5kVA	8.8KVA	11KVA
Rated Grid Frequency	50Hz / 60Hz		
Rated Grid Voltage	230V / 400V, 3L+N+PE / 3L+PE		
Power Factor	-0.8~+0.8(adjustable)		
THDi	<3% (at rated power)		

GENERAL DATA

Operating Temperature Range	-25°C ~+60°C	-25°C ~+60°C
Cooling Method	Natural Cooling	Smart Cooling
Protection Degree	IP65	IP65
Noise	<30dB	<50dB
Highest Altitude	3000m	3000m
Relative Humidity	0~100%	0~100%
Topology	Transformerless	Transformerless
Night Power Consumption	<0.5W	<0.5W
Max. Efficiency	98.10%	98.30%
European Efficiency	97.60%	97.80%
MPPT Efficiency	99.90%	99.90%
Display	LCD	
System Language	English / Chinese / German / Dutch / Polish	
Communication	Standard: RS485, Optional: WiFi / GPRS / Ethernet	

PROTECTION & CERTIFICATIONS

Protection	DC breaker, AC short-circuit protection, Over current protection, Over voltage protection, Insulation impedance protection, RCD, Surge protection, Anti-islanding protection, Over temperature protection, Groundfault monitoring, etc.
Grid	IEC 61727:2004, IEC62116:2014, IEC 60068-2-1:2007, IEC 60068-2-2:2007, IEC 60068-2-14:2009, IEC 60068-2-30:2005, IEC 61683:1999, DIN VDE 0126-1-1:2013, DIN VDE V 0124-100:2020, VDE-AR-N 4105:2018, C10/11:2019, AS/NZS 4777.2:2020, NB/T 32004-2018, PEA, ZVR, etc.
Connection	
Safety / EMC	IEC/EN 62109-1:2010, IEC/EN 62109-2:2011, EN 61000-6-2:2019, EN 61000-6-3:2007/A1:201



Model No:
SKU Code:

NEW

Three Phase On-Grid Solar Inverter

6kW

SUN-6K-G06P3-EU-BM2-P1
12662

10kW

SUN-10K-G06P3-EU-BM2-P1
12663

15kW

SUN-15K-G06P3-EU-BM2-P1
12664

PV STRING INPUT DATA

Max. PV Input Power (kW)	9	15	22.5
Max. PV Input Voltage (V)		1100	
Start-up Voltage (V)		140	
MPPT Voltage Range (V)		120-1000	
Rated PV Input Voltage (V)		600	
Max. Operating PV Input Current (A)		13+13	13+26
Max. Input Short Circuit Current (A)		19.5+19.5	19.5+39
No. of MPP Trackers/ No. of Strings MPP Tracker		2/1+1	2/1+2

AC OUTPUT DATA

Rated AC Output Active Power (kW)	6	10	15
Max. AC Output Apparent Power (kVA)	6.6	11	16.5
Rated AC Output Current (A)	9.1/8.7	15.2/14.5	22.8/21.8
Max. AC Output Current (A)	10/9.6	16.7/16	25/24
Rated Output Voltage/Range (V)	220/380V, 230/400V 0.85Un-1.1Un		
Grid Connection Form	3L/N/PE		
Rated Output Grid Frequency/Range(Hz)	50/45-55, 60/55-65		
Power Factor Adjustment Range	0.8 leading to 0.8 lagging		
Total Current Harmonic Distortion THDi	<3%		
DC Injection Current	<0.5%In		

GENERAL DATA

Operating Temperature Range (°C)	-25 to +60°C, >45°C Derating		
Permissible Ambient Humidity	0-100%		
Permissible Altitude (m)	4000m		
Noise (dB)	<45		
Ingress Protection(IP) Rating	IP 65		
Inverter Topology	Non-Isolated		
Over Voltage Category	OVC II(DC), OVC III(AC)		
Warranty	5 Years		
Type of Cooling	Natural Cooling		
Cabinet Size (WxHxD mm)	98.2%	98.3%	98.5%
Weight (kg)	97.6%	97.8%	98%
Max. Efficiency	>99%	>99%	>99%
Euro Efficiency			
MPPT Efficiency			

Safety / EMC

Grid Regulation

PROTECTION & CERTIFICATIONS

DC Reverse Polarity Protection, AC Output Overcurrent Protection
AC Output Overvoltage Protection, AC Output Short Circuit Protection
Thermal Protection, Insulation Impedance Detection, DC Component Monitoring,
Arc Fault Circuit Interrupter (AFCI)(optional), DC Switch, Anti-islanding Protection,
Residual Current Detection, Surge Protection Level: TYPE II(DC), TYPE II(AC)

IEC/EN 61000-6-1/2/3/4, IEC/EN 62109-1, IEC/EN 62109-2

IEC 61727, IEC 62116, CEI 0-21, EN 50549, NRS 097, RD 140, UNE 217002, OVE-Richtlinie R25, G98, G99, VDE-AR-N 4105

10
 YEAR
 WARRANTY

Three Phase On-Grid Solar Inverter

	5kW	8kW	10kW	15kW
Model No:	VT-6605310	VT-6608310	VT-6610310	VT-61015
SKU Code:	11381	11382	11383	11630
Net Weight:	12kg	13.50kg	13.50kg	13.50kg
Size(MM):	430 x 380 x 130	430 x 380 x 150	430 x 380 x 150	481 x 395 x 195

INPUT (DC)

	5kW	8kW	10kW	15kW
Max. Input Power	8kW	12.8kW	16kW	24kW
Max. Input Voltage	1100V	1100V	1100V	1100V
Start Voltage	160V	160V	160V	160V
Rated Input Voltage	600V	600V	600V	600V
Full-load MPP Voltage Range	250V ~ 850V	320V ~ 850V	450V ~ 850V	500V ~ 850V
MPPT Voltage Range	140V ~ 1000V	140V ~ 1000V	140V ~ 1000V	180V ~ 1000V
Number of MPP Trackers / String per MPPT	2 / 1	2 / 1	2 / 1	2 - 1 / 2
Max. Current per MPPT	13A	13A	13A	14A / 28A
Max. Short Circuit Current per MPPT	16A	16A	16A	18A / 36A

AC OUTPUT DATA

	5kW	8kW	10kW	15kW
Max. Output Current	8A	12.8A	15.9A	23.9A
Rated AC Power	5kW	8kW	10kW	15kW
Max. Output Power	5.5kVA	8.8kVA	11kVA	16.5kVA
Rated Grid Frequency	50Hz / 60Hz			
Rated Grid Voltage	230Vac / 400Vac, 3L / N / PE			
Power Factor	>0.99 (0.8 leading~0.8 lagging)			
THDi	<3% (Rated Power)			

GENERAL DATA

	5kW	8kW
Operating Temperature Range	-25°C ~+60°C	-25°C ~+60°C
Cooling Method	Natural Cooling	Natural Cooling
Protection Degree	IP65	IP65
Highest Altitude	4000m	4000m
Relative Humidity	0~100%	0~100%
Topology	Transformerless	Transformerless
Night Power Consumption	<0.5W	<0.5W
Max. Efficiency	98.40%	98.70%
European Efficiency	98.30%	98.50%
MPPT Efficiency	99.90%	99.90%
Display	LED / LCD (Optional)	
Communication	Standard:RS485 / USB - Optional: WiFi / GPRS / Ethernet	

PROTECTION & CERTIFICATIONS

Protection	DC reverse polarity protection, Anti-islanding protection, AC short circuit protection, Residual current monitoring unit, Insulation resistance monitoring, Ground fault monitoring, Grid monitoring, Surge protection (Type II), AFCI protection
Grid Connection	IEC 61727, IEC 62116, IEC 60068, IEC 61683, VDE-AR-N 4110:2018, VDE-AR-N 4105:2018, VDE-AR-N 4120:2018, EN 50549, AS/NZS 4777.2:2015, CEI 0-21, VDE 0126-1-1/A1 VFR 2014, UTE C15-712-1:2013, DEWA DRRG, NRS 097-2-1, MEA/PEA, C10/11, G98/G99
Safety / EMC	IEC 62109-1:2010, IEC 62109-2:2011, EN 61000-6-2:2005, EN 61000-6-3:2007/A1:2011



Three Phase On-Grid Solar Inverter

30kW



Model No:	SUN-30K-G04
SKU Code:	11812
Net Weight:	23 kg
Size(MM):	362×577×21

INPUT (DC)

Max. DC Input Power (kW)	39
Max. DC Input Voltage (V)	1000
Start-up DC Input Voltage (V)	250
MPPT Operating Range (V)	200-850
Max. DC Input Current (A)	40+40
Max. Short Circuit Current (A)	60+60
No.of MPP Trackers	2
No.of Strings per MPP Tracker	3 +3

AC OUTPUT DATA

Rated Output Power (kW)	30
Max. Active Power (kW)	33
Nominal Output Voltage / Range (V)	3L/N/PE 220/380V, 230/400V
Rated Grid Frequency (Hz)	50 / 60 (Optional)
Operating Phase	Three Phase
Rated AC Grid Output Current (A)	45.5/43.5
Max. AC Output Current (A)	50/47.9
Output Power Factor	0.8 leading to 0.8 lagging
Grid Current THD	<3%
DC Injection Current (mA)	<0.5%
Grid Frequency Range	45~55 or 55~65 (Optional)

GENERAL DATA

Topology	Transformerless
Internal Consumption	<1W (Night)
Running Temperature	-25-65°C, >45°C Derating
Ingress Protection	IP65
Noise Emission (Typical)	≤50 dB
Cooling Concept	Smart Cooling
Permissible Altitude (m)	2000
Max. Efficiency	98.60%
European Efficiency	97.80%
MPPT Efficiency	>99%
DC Connection	MC-4 Mateable
AC Connection	IP65 Rated Plug
Display	LCD1602
Interface	RS485/RS232/Wifi/LAN

PROTECTION & CERTIFICATIONS

Protection	DC Reverse-Polarity Protection, AC Short Circuit Protection, AC Output Overcurrent Protection, Output Overvoltage Protection, Insulation Resistance Protection, Ground Fault Monitoring, Anti-islanding Protection, Temperature Protection, Integrated DC Switch, Remote Software Upload, Remote Change of Operating Parameters, Surge Protection(DC Type II, AC Type II)
Grid-connection	VDE4105, IEC61727/62116, VDE0126, AS4777.2, CEI 0 21, EN50549-1, G98, G99, C10-11, UNE217002, NBR16149/NBR16150
Safety EMC / Standard	IEC/EN 61000-6-1/2/3/4, IEC/EN 62109-1, IEC/EN 62109-2

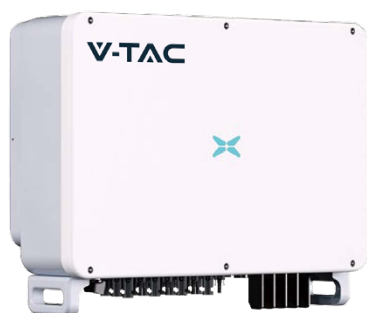

Three Phase On-Grid Solar Inverter



50kW

60kW

Model No:	VT-6607150
SKU Code:	11521
Net Weight:	50kg
Size(MM):	650 x 450 x 260

Model No:	VT-61060
SKU Code:	11631
Net Weight:	50kg
Size(MM):	650 x 450 x 260

INPUT (DC)

Max. Input Power	80kW	96kW
Max. Input Voltage	1100V	1100V
Start Voltage	250V	250V
Rated Input Voltage	600V	600V
Full-load MPP Voltage Range	520V ~ 850V	520V ~ 850V
MPPT Voltage Range	200V ~ 1000V	200V ~ 1000V
Number of MPP Trackers	4	4
Number of string per MPPT	3 / 2 / 3 / 2	3 / 3 / 3 / 3
Max. Current per MPPT	39A / 26A / 39A / 26A	39A
Max. Short Circuit Current per MPPT	48A / 32A / 48A / 32A	48A

AC OUTPUT DATA

Max. Output Current	79.7A	95.6A
Rated Output Power	50kW	60kW
Max. Output Power	55kVA	66kVA
Rated Grid Frequency	50Hz / 60Hz	50Hz / 60Hz
Rated Grid Voltage	230Vac / 400Vac	230Vac / 400Vac
Power Factor	>0.99 (0.8 leading~0.8 lagging)	>0.99 (0.8 leading~0.8 lagging)
THDi	<3% (Rated Power)	<3% (Rated Power)

GENERAL DATA

Operating Temperature Range	-30° C ~ +60° C
Cooling Method	Smart Cooling
Protection Degree	IP66
Max. Operating Altitude	4000m
Relative Humidity	0 ~ 100%
Topology	Transformerless
Night Power Consumption	<1W
Max. Efficiency	98.70%
European Efficiency	98.40%
MPPT Efficiency	99.90%
Display	LED / LCD / WiFi+App (Optional)
Communication	Standard:RS485 / USB , Optional: WiFi / GPRS / Ethernet

PROTECTION & CERTIFICATIONS

Protection	DC reverse polarity protection, Anti-islanding protection, AC short circuit protection, Residual current monitoring unit, Insulation resistance monitoring, Ground fault monitoring, Grid monitoring, Surge protection (Type II), AFCI protection
Grid Connection	IEC 61727, IEC 62116, IEC 60068, IEC 61683, VDE-AR-N 4110:2018, VDE-AR-N 4105:2018, VDE-AR-N 4120:2018, EN 50549, AS/NZS 4777.2:2020, CEI 0-21, VDE 0126-1-1/A1 VFR 2014, UTE C15-712-1:2013, DEWA DRRG, NRS 097-2-1, MEA/PEA, C10/11, G98/G99
Safety / EMC	IEC 62109-1:2010, IEC 62109-2:2011, EN 61000-6-2:2005, EN 61000-6-3:2007/A1:2011

Three Phase On-Grid Solar Inverter



100kW

Model No:	VT-6607100
SKU Code:	11520
Net Weight:	95kg
Size(MM):	1050 x 660 x 330

INPUT (DC)

Max. Input Power	150kW
Max. Input Voltage	1100V
Start Voltage	250V
Rated Input Voltage	620V
Full-load MPP Voltage Range	530V ~ 850V
MPPT Voltage Range	180V ~ 1000V
Number of MPP Trackers	9
Number of string per MPPT	2
Max. Current per MPPT	26A
Max. Short Circuit Current per MPPT	40A

AC OUTPUT DATA

Max. Output Current	158.8A
Rated Output Power	100kW
Max. Output Power	110kVA
Rated Grid Frequency	50Hz / 60Hz
Rated Grid Voltage	230Vac / 400Vac, 3L / N / PE, 3L / PE
Power Factor	>0.99 (0.8 leading~0.8 lagging)
THDi	<3% (Rated Power)

GENERAL DATA

Operating Temperature Range	-30° C ~ +60° C
Cooling Method	Smart Cooling
Protection Degree	IP66
Max. Operating Altitude	4000m
Relative Humidity	0 ~ 100%
Topology	Transformerless
Night Power Consumption	<1W
Max. Efficiency	98.70%
European Efficiency	98.50%
MPPT Efficiency	99.90%
Display	LED / LCD / WiFi+App (Optional)
Communication	Standard:RS485 / USB , Optional: WiFi / GPRS / Ethernet

PROTECTION & CERTIFICATIONS

Protection	DC reverse polarity protection, Anti-islanding protection, AC short circuit protection, Residual current monitoring unit, Insulation resistance monitoring, Ground fault monitoring, Grid monitoring, V string monitoring, Surge protection (Type II) AFCI protection (Optional), PID recovery function (Optional), SVG function (Optional)
Grid	IEC 61727, IEC 62116, IEC 60068, IEC 61683, VDE-AR-N 4110:2018, VDE-AR-N 4105:2018, VDE-AR-N 4120:2018, EN 50549, AS/NZS 4777.2:2020, CEI 0-21, VDE 0126-1-1/A1 VFR 2014, UTE C15-712-1:2013, DEWA DRRG, NRS 097-2-1, MEA/PEA, C10/11, G98/G99
Connection	
Safety / EMC	IEC 62109-1:2010, IEC 62109-2:2011, EN 61000-6-2:2005, EN 61000-6-3:2007/A1:2011



Single Phase Hybrid Solar Inverter

3.6kW

Model No: **VT-6607136**
 SKU Code: **11576 - 11955 Italian**

10 YEAR
WARRANTY

CEI 0-21
CERTIFICATE

G98-G99
CERTIFICATE

PV INPUT

Max. Input Power(kW)	5.4
Max. PV Voltage(V)	550
MPPT Range(V)	80-500
full MPPT Range(V)	210-500
Normal Voltage(V)	360
Startup Voltage(V)	100
Max. Input Current(A)	18.5*1
Max. Short Current(A)	26*1
No. of MPP Tracker / No. of PV String	1.0/1.0

AC LOAD OUTPUT

Nominal AC Voltage L-N(V)	220 / 230
Nominal AC Frequency(Hz)	50 / 60
Nominal AC Current(A)	16.4/15.7
Max Continuous Current(A)	17.0
Max Continuous Power(kVA)	3.6
Max Peak Current(A)(10min)	24.6/23.5
Max Peak Power(kVA)(10min)	5.4
Switching Time(s)	Seamless
Voltage THD(%)	< 3

BATTERY PORT

Battery Type	Li-ion / Lead-acid
Battery Voltage Range(V)	40-60
Battery Normal Voltage(V)	51.2
Max. Charge/Discharge Current(A)	80
Max. Charge/Discharge Power(kW)	3.6

AC GRID

Nominal Grid Voltage(V)	220 / 230
Nominal Grid Frequency(Hz)	50 / 60
Nominal Grid Current(A)	16.4/15.7
Max Continuous Current(A)	17.0
Max Continuous Power(kVA)	3.6
Current THD(%)	< 3
Power Factor	0.999 (Adjustable from 0.8 overexcited to 0.8 underexcited)

GENERAL DATA

Dimensions (L x W x H, mm)	513 x 370 x 192
Weight (kg)	17
Topology	Transformerless
Cooling	Intelligent Fan
Relatively Humidity	0 - 100 %
Operating Temperature Range (°C)	- 25 to 60
Operating Altitude (m)	< 4000
Noise Emission (dB)	< 25
Standby Consumption (W)	< 10
Mounting	Wall Bracket
Communication with RSD	SUNSPEC
Display & Communication Interfaces	LCD, LED, RS485, CAN, Wi-Fi, GPRS, 4G

EFFICIENCY

CEC Efficiency(%)	97
Max. Efficiency(%)	97.6
PV to Bat. Efficiency(%)	98.1
Bat. between AC Efficiency(%)	96.8

PROTECTION & CERTIFICATIONS

Protection **PV Reverse Polarity Protection, Over Current/Voltage Protection, Anti-Islanding Protection, AC Short Circuit Protection, Residual Current Detection, Ground Fault Monitoring, Insulation Resister Detection, PV Arc Detection, Enclosure Protect Level**

Certification & Approvals **NRS97, G98/G99, EN50549-1, C10/C11, AS 4777, VDE-AR-N4105,VDE0126, IEC62040, IEC62109-1, IEC62109-2**

EMC **EN61000-6-2, EN61000-6-3**

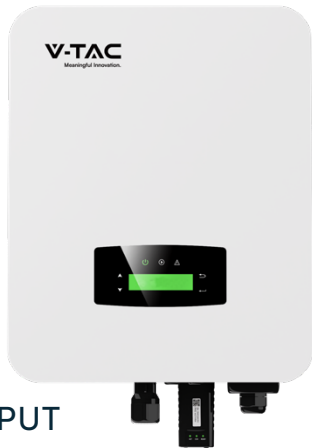

Single Phase Hybrid Solar Inverter

5kW

Model No: VT-6607105
SKU Code: 11819

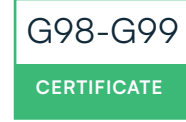

PV INPUT

Max. Input Power(kW)	7.5
Max. PV Voltage(V)	550
MPPT Range(V)	80-500
full MPPT Range(V)	150-500
Normal Voltage(V)	360
Startup Voltage(V)	100
Max. Input Current(A)	18.5*2
Max. Short Current(A)	26*2
No. of MPP Tracker / No. of PV String	2/2

AC LOAD OUTPUT

Nominal AC Voltage L-N(V)	220 / 230
Nominal AC Frequency(Hz)	50 / 60
Nominal AC Current(A)	22.8/21.8
Max Continuous Current(A)	23.0
Max Continuous Power(kVA)	5.0
Max Peak Current(A)(10min)	34.1/32.7
Max Peak Power(kVA)(10min)	7.5
Switching Time(s)	Seamless
Voltage THD(%)	< 3

BATTERY PORT

Battery Type	Li-ion / Lead-acid
Battery Voltage Range(V)	40-60
Battery Normal Voltage(V)	51.2
Max. Charge/Discharge Current(A)	80
Max. Charge/Discharge Power(kW)	4.8

AC GRID

Nominal Grid Voltage(V)	220 / 230
Nominal Grid Frequency(Hz)	50 / 60
Nominal Grid Current(A)	22.8/21.8
Max Continuous Current(A)	23.0
Max Continuous Power(kVA)	5.0
Current THD(%)	< 3
Power Factor	0.999 (Adjustable from 0.8 overexcited to 0.8 underexcited)

GENERAL DATA

Dimensions (L x W x H, mm)	513 x 370 x 192
Weight (kg)	17
Topology	Transformerless
Cooling	Intelligent Fan
Relatively Humidity	0 - 100 %
Operating Temperature Range (°C)	- 25 to 60
Operating Altitude (m)	< 4000
Noise Emission (dB)	< 25
Standby Consumption (W)	< 10
Mounting	Wall Bracket
Communication with RSD	SUNSPEC
Display & Communication Interfaces	LCD, LED, RS485, CAN, Wi-Fi, GPRS, 4G

EFFICIENCY

CEC Efficiency(%)	97
Max. Efficiency(%)	97.6
PV to Bat. Efficiency(%)	98.1
Bat. between AC Efficiency(%)	96.8

PROTECTION & CERTIFICATIONS

Protection	PV Reverse Polarity Protection, Over Current/Voltage Protection, Anti-Islanding Protection, AC Short Circuit Protection, Residual Current Detection, Ground Fault Monitoring, Insulation Resister Detection, PV Arc Detection, Enclosure Protect Level
Certification & Approvals	NRS97, G98/G99, EN50549-1, C10/C11, AS 4777, VDE-AR-N4105,VDE0126, IEC62040, IEC62109-1, IEC62109-2
EMC	EN61000-6-2, EN61000-6-3

Single Phase Hybrid Solar Inverter

5kW

Model No: **VT-6607103**SKU Code: **11509**
05
 YEAR
 WARRANTY

G98-G99
 CERTIFICATE

INPUT (PV)

Max. PV Input Power	7kW
Max. PV Input Voltage	550V
MPP Voltage Range	125V ~ 500V
Max. PV Input Current	14A
Number of MPP Trackers	2
String per MPPT	1

OUTPUT (EPS)

Rated Power	5kVA
Rated Voltage	230Vac
Rated Current	21.7A
Rated Frequency	50Hz / 60Hz
Automatic Switching Time	<20ms
Overload Capability	110%, 30s / 120%, 10s / 150%, 0.02s
THDu	<2%

OUTPUT (AC)

Max. Output Current	21.7A
Rated Power	5kW
Rated Voltage	230V, L + N + PE
Operating Voltage Range	176V ~ 270V
Frequency	50Hz / 60Hz
Power Factor	0.8 lagging~0.8 leading
THDi	<3%

BATTERY

Battery Voltage Range	40V ~ 58V
Max. Charging Voltage	58V
Charge / Discharge Current	95A / 104.2A
Battery Type	Lithium / Lead-acid
Communication	RS485, CAN

EFFICIENCY

Max. DC Efficiency	97.60%
European Efficiency	97.00%
MPPT Efficiency	99.90%
Battery Charge / Discharge Efficiency	95.00%

GENERAL DATA

Dimensions (L x W x H, mm)	550 x 515 x 200
Weight (kg)	25kg
Operation Temperature	-25°C~ +60°C
Cooling Method	Natural Cooling
Protection Degree	IP65
Noise Emission	<35dB
Max. Operating Altitude	2000m
Relative Humidity	0 ~ 95% (non-condensing)
Topology	Transformerless
Standby Power Consumption	<3W

COMMUNICATION

Display	LCD
Communication	Standard: RS485 / CAN / DRM Optional: WIFI / 4G

STANDARD COMPLIANCE

Certifications	CE, TUV, SAA, NRS
----------------	-------------------

Single Phase Hybrid Solar Inverter

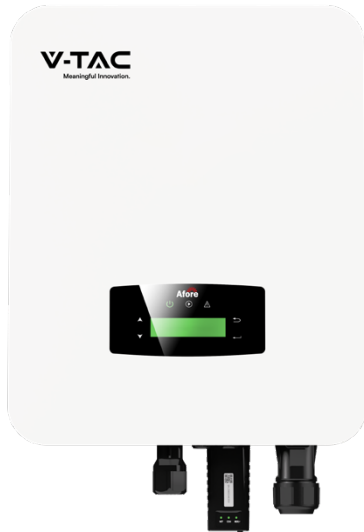

6kW

Model No: VT-AF6K-SLP
SKU Code: 11953



INPUT (PV)

Max. Input Power (kW)	9.0
Max. PV Voltage (V)	550
MPPT Range (V)	80 - 500
Full MPPT Range (V)	170 - 500
Normal Voltage (V)	360
Startup Voltage (V)	100
Max. Input Current (A)	18.5 x 2
Max. Short Current (A)	26 x 2
No. of MPP Tracker / No. of PV String	2 / 2

OUTPUT (AC)

Max Continuous Current (A)	28.0
Max Continuous Power (kVA)	6.0
Max Peak Current (A) (10min)	41.0 / 39.2
Max Peak Power (kVA) (10min)	9.0
Nominal AC Current (A)	27.3 / 26.1
Nominal AC Voltage L-N (V)	220 / 230
Nominal AC Frequency (Hz)	50 / 60
Switching Time (s)	Seamless
Voltage THD (%)	< 3

COMMUNICATION

Display	LCD, LED
Communication	RS485, CAN, Wi-Fi, GPRS, 4G

STANDARD COMPLIANCE

Certification & Approvals	NRS97, G98/G99, EN50549-1, C10/C11, AS 4777, VDE-AR-N4105, VDE0126, IEC62040, IEC62109-1, IEC62109-2
EMC	EN61000-6-2, EN61000-6-3

BATTERY

Max. Charge/Discharge Power (kW)	4.8
Max. Charge/Discharge Current (A)	80
Battery Normal Voltage (V)	51.2
Battery Voltage Range (V)	40 - 60
Battery Type	Li-ion / Lead-acid

AC GRID

Max Continuous Current (A)	28.0
Max Continuous Power (kVA)	6.0
Nominal Grid Current(A)	27.3 / 26.1
Nominal Grid Voltage (V)	198 to 242 @ 220 / 207 to 253 @ 230
Nominal Grid Frequency (Hz)	50 / 60
Current THD (%)	< 3
Power Factor	0.999 (Adjustable from 0.8 overexcited to 0.8 underexcited)

EFFICIENCY

CEC Efficiency (%)	97.0
Max. Efficiency (%)	97.6
PV to Bat. Efficiency (%)	98.1
Bat. between AC Efficiency (%)	96.8

GENERAL DATA

Dimensions (L x W x H, mm)	513 x 370 x 192
Weight (kg)	17
Topology	Transformerless
Cooling	Intelligent Fan
Relatively Humidity	0 - 100 %
Operating Temperature Range (°C)	- 25 to 60
Operating Altitude (m)	< 4000
Noise Emission (dB)	< 25
Standby Consumption (W)	< 10
Mounting	Wall Bracket
Communication with RSD	SUNSPEC

Single Phase Low-voltage Hybrid Inverters

3.6KW

5kW

6kW

Model No: Isuna 3600S
SKU Code: 12157

Model No: Isuna 5000S
SKU Code: 12158

Model No: Isuna 6000S
SKU Code: 12156

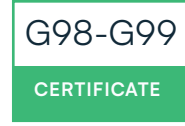

Higher Reliability

IP65 Outdoor and Indoor use
Natural cooling, Ultra silence
SiC technology, Longer lifespan
Plug-in design, Easy to install

High Capability

15 units in parallel
2 independent ports for battery
Support mixture use of old & new battery

Auto sleep
VPP interface ready
Cloud + Smart data analysis

Smart Monitoring

UPS function
Flexible DO control
10ms on/off-grid switchover
100% three phase unbalance

Strong Load Adaptability

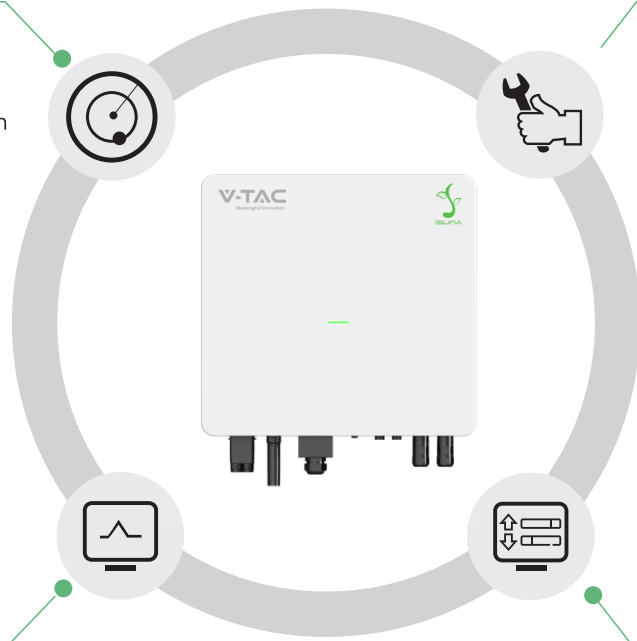

GENERAL DATA

Size(L*W*H)	500mm*470mm*180mm
Weight	21kg
Noise	<25dB(A)
Operating Temperature Range	-25°C~+60°C
Cooling Method	Natural cooling
Ingress Protection Grade	IP65
Monitoring	H5/LED/APP/WIFI/4G/Bluetooth
Communication Port	RS485/CAN/DRED/DO/Parallel port





Model No:
SKU Code:

3.6KW

Model No: **VT-Isuna 3600S**
SKU Code: **12157**

5kW

Model No: **VT-Isuna 5000S**
SKU Code: **12158**

6kW

Model No: **VT-Isuna 6000S**
SKU Code: **12156**

OFF-GRID OUTPUT

Nominal Output Power	3600W	5000W	6000W
Nominal Voltage	230V	230V	230V
Nominal Frequency	50/60Hz	50/60Hz	50/60Hz
Nominal Output Current	16.4A	22.7A	27.2A
THDu	<2%	<2%	<2%

ON-GRID PARAMETER

Nominal Output Power	3600W	5000W	6000W
Max. Output Current	16.4A	22.7A	27.2A
Nominal Grid Voltage	230V	230V	230V
Max. Output Current from Grid	22.7A	27.2A	22.2A
Grid Voltage Range	184-264V	184-264V	184-264V
Frequency Range	45-65Hz	45-65Hz	45-65Hz

PV INPUT

Max. Input Power	6000Wp	7500Wp	9000Wp
Starting Voltage	95V	95V	95V
Max. Input Voltage	600V	600V	600V
MPPT Voltage Range	80-550V	80-550V	80-550V
Full Load MPPT Voltage Range	350-500V	350-500V	350-500V
Number of MPPT	2	2	2
Max. Input String Per MPPT	1	1	1
Nominal Input Voltage	360V	360V	360V
Max. Input Current	18A/18A	18A/18A	18A/18A

BATTERY PARAMETER

Battery Type	Lithium-ion battery	Lithium-ion battery	Lithium-ion battery
Nominal Battery Voltage	51.2V	51.2V	51.2V
Battery Voltage Range	42-58V	42-58V	42-58V
Max. Charging Voltage	≤60V	≤60V	≤60V
Max. Charging/Discharging Current	85A	100A	100A

PROTECTION & CERTIFICATIONS

Protection	DC Switch, PV Insulation Resistance Detection, Residual Current Monitoring, Anti-islanding Protection, Reverse Polarity Protection(PV), AC Short Circuit Protection, AC Overcurrent Protection, AC Overvoltage Protection, Surge Protection, Lightning Protection II
CE_LVD	IEC 62109-1, IEC 62109-2, EN 62109-1, EN 62109-2
CE_EMC	EN61000-6-1, EN61000-6-2, EN61000-6-3, EN61000-6-4
Grid	VDE-AR-N 4105, G99, CEI 0-21, EN50549, NRS 097-2-1, R25,C10-11,NTS 2.1

Single Phase Hybrid Solar Inverter



NEW

10 YEAR WARRANTY

Model No: **SUN-3.6K-SG05LP1-EU-AM2-P**
SKU Code: **12344**

3.6kW

AC INPUT/OUTPUT DATA

Rated AC Input/Output Active Power (W)	3600
Max. AC Input/Output Apparent Power (VA)	3960
Rated AC Input/Output Current (A)	16.4/15.7
Max. AC Input/Output Current (A)	18/17.2
Max. Continuous AC Passthrough (grid to load) (A)	35
Peak Power (off-grid) (W)	2 times of rated power, 10s
Power Factor Adjustment Range	0.8 leading to 0.8 lagging
Rated Input/Output Voltage/Range (V)	220/230 0.85Un-1.1Un
Rated Input/Output Grid Frequency/Range(Hz)	50/45-55, 60/55-65
Grid Connection Form	L+N+PE
Total Current Harmonic Distortion THDi	<3% (of nominal power)
DC Injection Current	<0.5% In

PV STRING INPUT DATA

Max. PV Access Power (W)	7200
Max. PV Input Power (W)	5760
Max. PV Input Voltage (V)	500
Start-up Voltage (V)	125
MPPT Voltage Range (V)	150-425
Rated PV Input Voltage (V)	370
Max. Operating PV Input Current (A)	18+18
Max. Input Short-Circuit Current (A)	27+27
No. of MPP Trackers/ No. of Strings MPP Tracker	2/1+1

GENERAL DATA

Operating Temperature Range ()	-40 to +60°C, >45° C Derating
Permissible Ambient Humidity	0-100%
Permissible Altitude	2000m
Noise (dB)	<30
Ingress Protection(IP) Rating	IP 65
Inverter Topology	Non-Isolated
Over Voltage Category	OVC II(DC), OVC III(AC)
Cabinet Size (WxHxD mm)	330×580×232
Weight (kg)	24.9
Type of Cooling	Intelligent Air Cooling

BATTERY PORT

Battery Type	Lead-acid or Lithium-ion
Battery Voltage Range (V)	40-60
Max. Charging Current (A)	90
Max. Discharging Current (A)	90
Charging Strategy for Li-ion Battery	Self-adaption to BMS
Number of Battery Input	1

EFFICIENCY

Max. Efficiency	97.6%
Euro Efficiency	96.5%
MPPT Efficiency	>99%

PROTECTION & CERTIFICATIONS

Integrated DC Polarity Reverse Connection Protection, AC Output Overcurrent Protection, Thermal Protection, AC Output Overvoltage Protection, AC Output Short Circuit Protection, DC Component Monitoring, Overvoltage Load Drop Protection, Ground Fault Current Monitoring, Arc Fault Circuit Interrupter (optional), Power Network Monitoring, Island Protection Monitoring, Earth Fault Detection, DC Input Switch, DC Terminal Insulation Impedance Monitoring, Residual Current (RCD) Detection, Surge protection level, Surge Protection Level: TYPE II(DC), TYPE II(AC)

Grid Regulation IEC 61727, IEC 62116, CEI 0-21, EN 50549, NRS 097, RD 140, UNE 217002, OVE-Richtlinie R25, G98, G99, VDE-AR-N 4105

Safety EMC / Standard IEC/EN 61000-6-1/2/3/4, IEC/EN 62109-1, IEC/EN 62109-2



Single Phase Hybrid Solar Inverter

10 YEAR WARRANTY

Model No: **SUN-3.6K-SG03LP1-EU**
SKU Code: **11725**

3.6kW

CEI 0-21
CERTIFICATE

PV INPUT

Max. DC Input Power (W)	4680
Rated PV Input Voltage (V)	370 (125-500)
Start-up Voltage (V)	125
MPPT Voltage Range (V)	150-425
Full Load DC Voltage Range (V)	300-425
PV Input Current (A)	13+13
Max. PV ISC (A)	17+17
No.of MPP Trackers	2
No.of Strings per MPP Tracker	1+1

BATTERY PORT

Battery Type	Li-ion / Lead-acid
Battery Voltage Range(V)	40-60
Battery Normal Voltage(V)	51.2
Max. Charge/Discharge Current(A)	80
Max. Charge/Discharge Power(kW)	3.6

GENERAL DATA

Dimensions (Wx H x D, mm)	513 x 370 x 192
Weight (kg)	17
Topology	Transformerless
Cooling	Intelligent Fan
Relatively Humidity	0 - 100 %
Operating Temperature Range (°C)	- 25 to 60
Operating Altitude (m)	< 4000
Noise Emission (dB)	< 25
Standby Consumption (W)	< 10
Mounting	Wall Bracket
Communication with RSD	SUNSPEC
Display & Communication Interfaces	LCD, LED, RS485, CAN, Wi-Fi, GPRS, 4G

AC LOAD OUTPUT

Nominal AC Voltage L-N(V)	220 / 230
Nominal AC Frequency(Hz)	50 / 60
Nominal AC Current(A)	16.4/15.7
Max Continuous Current(A)	17.0
Max Continuous Power(kVA)	3.6
Max Peak Current(A)(10min)	24.6/23.5
Max Peak Power(kVA)(10min)	5.4
Switching Time(s)	Seamless
Voltage THD(%)	< 3

AC GRID

Nominal Grid Voltage(V)	220 / 230
Nominal Grid Frequency(Hz)	50 / 60
Nominal Grid Current(A)	16.4/15.7
Max Continuous Current(A)	17.0
Max Continuous Power(kVA)	3.6
Current THD(%)	< 3
Power Factor	0.999 (Adjustable from 0.8 overexcited to 0.8 underexcited)

EFFICIENCY

Max. Efficiency	97.60%
Euro Efficiency	96.50%
MPPT Efficiency	99.90%

PROTECTION & CERTIFICATIONS

Protection **PV Reverse Polarity Protection, Over Current/Voltage Protection, Anti-Islanding Protection, AC Short Circuit Protection, Residual Current Detection, Ground Fault Monitoring, Insulation Resister Detection, PV Arc Detection, Enclosure Protect Level**

Certification & Approvals **NRS97, G98/G99, EN50549-1, C10/C11, AS 4777, VDE-AR-N4105,VDE0126, IEC62040, IEC62109-1, IEC62109-2**

Single Phase Hybrid Solar Inverter



Model No: **SUN-5K-SG03LP1-EU**
SKU Code: **11547- WHITE**
12309- BLACK

5kW



AC LOAD OUTPUT

Rated AC Output and UPS Power (W)	5000
Max. AC Output Power (W)	5500
AC Output Rated Current (A)	25/23.9
Max. AC Current (A)	22.7/21.7
Max. Continuous AC Passthrough (A)	35
Peak Power (off grid)	2 time of rated power, 10 S
Power Factor	0.8 leading to 0.8 lagging
Grid Type	THD<3% (Linear load<1.5%)
DC injection current (mA)	Single Phase
Output Frequency and Voltage	50/60Hz; L/N/PE 220/230Vac

GENERAL DATA

Dimensions (Wx H x D, mm)	30W x 580H x232D
Weight (kg)	24kg
Operating Temperature Range (°C)	-40~60°C, >45°C derating
Cooling	Natural cooling
Noise (dB)	<30 dB
Communication with BMS	RS485; CAN
Protection Degree	IP65
Installation Style	Wall-mounted

EFFICIENCY

Max. Efficiency	97.60%
Euro Efficiency	96.50%
MPPT Efficiency	99.90%

PV INPUT

Max. DC Input Power (W)	6500
Rated PV Input Voltage (V)	370 (125~500)
Start-up Voltage (V)	125
MPPT Voltage Range (V)	150-425
Full Load DC Voltage Range (V)	300-425
PV Input Current (A)	13+13
Max. PV ISC (A)	17+17
No.of MPP Trackers	2
No.of Strings per MPP Tracker	1

BATTERY PORT

Battery Type	Lead-acid or Li-Ion
Battery Voltage Range (V)	40~60
Max. Charging Current (A)	120
Max. Discharging Current (A)	120
External Temperature Sensor	Yes
Charging Curve	3 Stages / Equalization
Charging Strategy for Li-Ion Battery	Self-adaption to BMS

PROTECTION & CERTIFICATIONS

Integrated **PV Input Lightning Protection, Anti-islanding Protection, PV String Input Reverse Polarity Protection, Insulation Resistor Detection, Residual Current Monitoring Unit, Output Over Current Protection, Output Shorted Protection, Surge protection**

Output Over Voltage Protection **DC Type II/AC Type III**

Grid Regulation **VDE4105, IEC61727/62116, VDE0126, AS4777.2, CEI 0 21, EN50549-1, G98, G99, C10-11, UNE217002, NBR16149/NBR16150**



Single Phase Low Voltage Energy Storage Inverters

5kW



Model No: **S6-EH1P5K-L-PLUS**
SKU Code: **12290**

INPUT DC (PV SIDE)

Recommended max. PV array size	10 kW
Max. usable PV input power	8 kW
Max. input voltage	500 V
Rated voltage	330 V
Start-up voltage	90 V
MPPT voltage range	90-435 V
Max. input current	16 A / 16 A
Max. short circuit current	20 A / 20 A
MPPT number/Max. input strings number	2/2

INPUT AC (GRID SIDE)

Input voltage range	187-253 V
Max. input current	32 A
Frequency range	45-55 Hz / 55-65 Hz

OUTPUT AC (GRID SIDE)

Rated output power	5 kW
Max. apparent output power	5 kVA
Operation phase	L/N/PE
Rated grid voltage	220 V / 230 V
Rated grid frequency	50 Hz / 60 Hz
Rated grid output current	22.8 A / 21.8 A
Max. output current	22.8 A / 21.8 A
Power factor	>0.99 (0.8 leading - 0.8 lagging)
THDi	<2%

OUTPUT AC (BACK-UP)

Rated output power	5 kW
Max. apparent output power	2 times of rated power, 10 s
Back-up switch time	<4 ms
Rated output voltage	L/N/PE, 220 V / 230 V
Rated frequency	50 Hz / 60 Hz
Rated output current	22.8 A / 21.8 A
Max. AC Passthrough current	40 A
THDv (@linear load)	<2%

BATTERY

Battery type	Li-ion / Lead-acid
Battery voltage range	40-60 V
Max. charge / discharge power	5 kW
Max. charge / discharge current	112 A
Communication	CAN/RS485

FEATURES

DC connection	MC4 plug (PV port) / Terminal Block (BAT port)
AC connection	Terminal Block
Display	LCD + Bluetooth + APP
Communication	RS485, CAN, Optional: Wi-Fi, GPRS, LAN

GENERAL DATA

Dimensions (W*H*D)	335*560*227 mm
Weight	21.6 kg
Topology	High frequency isolation (for battery)
Operating ambient temperature range	-40 ~ +60°C
Ingress protection	IP66
Cooling concept	Natural convection
Max. operation altitude	3000 m
Grid connection standard	NRS 097-2-1, IEC 62116, IEC 61727, IEC 60068, IEC 61683, EN 50530, MEA, PEA, NBR 16149, NBR 16150
Safety/EMC standard	IEC/EN 62109-1/-2, EN 61000-6-2/-3

EFFICIENCY

Max. efficiency	96.2%
EU efficiency	96.1%
BAT charged by PV/AC Max. efficiency	95.3%/93.9%
BAT discharged to AC Max. efficiency	93.8%

PROTECTION

Ground fault monitoring: Yes, DC reverse-polarity protection Yes,
Integrated AFCI 2.0: (Optional), Protection class/Over voltage category: I / II (PV and BAT), III (MAINS and BACKUP and GEN)



Single Phase Low Voltage Energy Storage Inverters

6kW

 Model No: **S6-EHIP6K-L-PLUS**

 SKU Code: **12223**

INPUT DC (PV SIDE)

Recommended max. PV array size	12 kW
Max. usable PV input power	9.6 kW
Max. input voltage	500 V
Rated voltage	330 V
Start-up voltage	90 V
MPPT voltage range	90-435 V
Max. input current	16 A / 16 A
Max. short circuit current	20 A / 20 A
MPPT number/Max. input strings number	2/2

INPUT AC (GRID SIDE)

Input voltage range	187-253 V
Max. input current	40 A
Frequency range	45-55 Hz / 55-65 Hz

OUTPUT AC (GRID SIDE)

Rated output power	6 kW
Max. apparent output power	6 kVA
Operation phase	L/N/PE
Rated grid voltage	220 V / 230 V
Rated grid frequency	50 Hz / 60 Hz
Rated grid output current	27.3 A / 26.1 A
Max. output current	27.3 A / 26.1 A
Power factor	>0.99 (0.8 leading - 0.8 lagging)
THDi	<2%

OUTPUT AC (BACK-UP)

Rated output power	6 kW
Max. apparent output power	2 times of rated power, 10 s
Back-up switch time	<4 ms
Rated output voltage	L/N/PE, 220 V / 230 V
Rated frequency	50 Hz / 60 Hz
Rated output current	27.3 A / 26.1 A
Max. AC Passthrough current	40 A
THDv (@linear load)	<2%

BATTERY

Battery type	Li-ion / Lead-acid
Battery voltage range	40-60 V
Max. charge / discharge power	6 kW
Max. charge / discharge current	135 A
Communication	CAN/RS485

FEATURES

DC connection	MC4 plug (PV port) / Terminal Block (BAT port)
AC connection	Terminal Block
Display	LCD + Bluetooth + APP
Communication	RS485, CAN, Optional: Wi-Fi, GPRS, LAN

GENERAL DATA

Dimensions (W*H*D)	335*560*227 mm
Weight	21.6 kg
Topology	High frequency isolation (for battery)
Operating ambient temperature range	-40 ~ +60°C
Ingress protection	IP66
Cooling concept	Intelligent redundant fan-cooling
Max. operation altitude	3000 m
Grid connection standard	NRS 097-2-1, IEC 62116, IEC 61727, IEC 60068, IEC 61683, EN 50530, MEA, PEA, NBR 16149, NBR 16150
Safety/EMC standard	IEC/EN 62109-1/-2, EN 61000-6-2/-3

EFFICIENCY

Max. efficiency	96.2%
EU efficiency	96.1%
BAT charged by PV/AC Max. efficiency	95.3%/93.9%
BAT discharged to AC Max. efficiency	93.8%

PROTECTION

Ground fault monitoring: Yes, DC reverse-polarity protection Yes,
 Integrated AFCI 2.0: (Optional), Protection class/Over voltage category: I / II (PV and BAT), III (MAINS and BACKUP and GEN)

EMC EN61000-6-2, EN61000-6-3

Single Phase Hybrid Solar Inverter

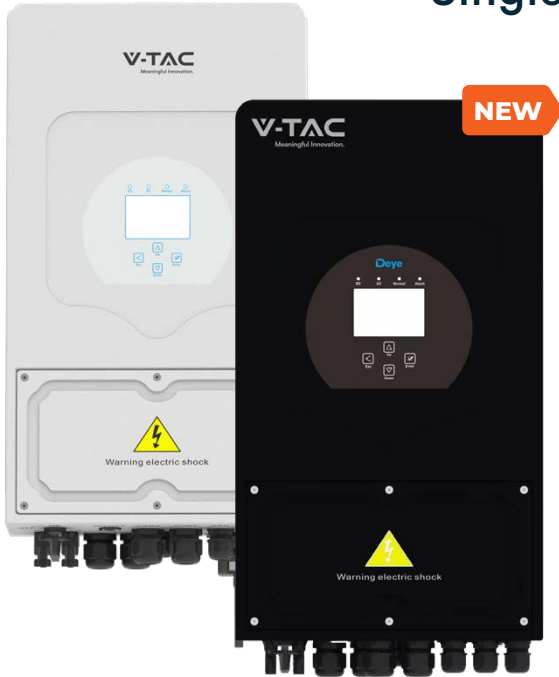

10 YEAR WARRANTY

6kW

Model No: **SUN-6K-SG05LP1-EU**

SKU Code: **11537**

11529- WHITE -ITALIAN SPECIFICATION

115291-BLACK -ITALIAN SPECIFICATION

CEI 0-21

CERTIFICATE

AC LOAD OUTPUT

Rated AC Output and UPS Power (W)	6000
Max. AC Output Power (W)	6600
AC Output Rated Current (A)	27.3/26.1
Max. AC Current (A)	30/28.7
Max. Continuous AC Passthrough (A)	40A
Peak Power (off grid)	2 time of rated power, 10 S
Power Factor	0.8 leading to 0.8 lagging
Grid Type	Single Phase
DC injection current (mA)	THD<3% (Linear load<1.5%)
Output Frequency and Voltage	50/60Hz; L/N/PE 220/230Vac

PV INPUT

Max. DC Input Power (W)	7800
Rated PV Input Voltage (V)	370 (125~500)
Start-up Voltage (V)	125
MPPT Voltage Range (V)	150-425
Full Load DC Voltage Range (V)	300-425
PV Input Current (A)	13+13
Max. PV ISC (A)	17+17
No.of MPP Trackers	2
No.of Strings per MPP Tracker	1

BATTERY PORT

Battery Type	Lead-acid or Li-Ion
Battery Voltage Range (V)	40~60
Max. Charging Current (A)	135
Max. Discharging Current (A)	135
External Temperature Sensor	Yes
Charging Curve	3 Stages / Equalization
Charging Strategy for Li-Ion Battery	Self-adaption to BMS

GENERAL DATA

Dimensions (Wx H x D, mm)	30W x 580H x 232D
Weight (kg)	24kg
Operating Temperature Range (°C)	-40~60°C, >45°C derating
Cooling	Natural cooling
Noise (dB)	<30 dB
Communication with BMS	RS485; CAN
Protection Degree	IP65
Installation Style	Wall-mounted

EFFICIENCY

Max. Efficiency	97.60%
Euro Efficiency	96.50%
MPPT Efficiency	99.90%

PROTECTION & CERTIFICATIONS

Integrated **PV Input Lightning Protection, Anti-islanding Protection, PV String Input Reverse Polarity Protection, Insulation Resistor Detection, Residual Current Monitoring Unit, Output Over Current Protection, Output Shorted Protection, Surge protection**

Output Over Voltage Protection **DC Type II/AC Type III**

Grid Regulation **VDE4105, IEC61727/62116, VDE0126, AS4777.2, CEI 0 21, EN50549-1, G98, G99, C10-11, UNE217002, NBR16149/NBR16150**

Safety EMC / Standard **IEC/EN 61000-6-1/2/3/4, IEC/EN 62109-1, IEC/EN 62109-2**



Single Phase Hybrid Solar Inverter

NEW

6kW

 Model No: **SUN-6K-SG05LP1-EU-AM2-P**
 SKU Code: **12679**

AC LOAD OUTPUT

Rated AC Input/Output Active Power (W)	6000
Max. AC Input/Output Apparent Power (VA)	6600
Rated AC Input/Output Current (A)	27.3/26.1
Max. AC Input/Output Current (A)	30/28.7
Max. Continuous AC Passthrough (grid to load) (A)	40
Peak Power (off-grid) (W)	2 times of rated power, 10s
Power Factor Adjustment Range	0.8 leading to 0.8 lagging
Rated Input/Output Voltage/Range (V)	220/230 0.85Un-1.1Un
Rated Input/Output Grid Frequency/Range(Hz)	50/45-55, 60/55-65
Grid Connection Form	L+N+PE
Total Current Harmonic Distortion THDi	<3% (of nominal power)
DC Injection Current	<0.5% In

BATTERY INPUT DATA

Battery Type	Lead-acid or Lithium-ion
Battery Voltage Range (V)	40-60
Max. Charging Current (A)	135
Max. Discharging Current (A)	135
Charging Strategy for Li-ion Battery	Self-adaption to BMS
Number of Battery Input	1

PV STRING INPUT DATA

Max. PV Access Power (W)	12000
Max. PV Input Power (W)	9600
Max. PV Input Voltage (V)	500
Start-up Voltage (V)	125
MPPT Voltage Range (V)	150-425
Rated PV Input Voltage (V)	370
Max. Operating PV Input Current (A)	32+32
Max. Input Short-Circuit Current (A)	48+48
No. of MPP Trackers/ No. of Strings MPP Tracker	2/2+2

GENERAL DATA

Operating Temperature Range	-40-60°C , >45°C Derating
Cooling	Intelligent Air Cooling
Noise (dB)	≤30 dB
Communication Interface	RS485/RS232/CAN
Weight (kg)	24.9
Cabinet Size (WxHxD mm)	330×580×232
Protection Degree	IP65
Installation Style	Wall-mounted

EFFICIENCY

Max. Efficiency	97.6%
Euro Efficiency	96.5%
MPPT Efficiency	>99%

PROTECTION & CERTIFICATIONS

Over Voltage Category DC Type II/AC Type III

Integrated DC Reverse Polarity Protection, AC Output Overcurrent Protection, Thermal Protection, AC Output Overvoltage Protection, AC Output Short Circuit Protection, DC Component Monitoring, Arc Fault Circuit Interrupter (optional), Anti-islanding Protection, DC Switch, Insulation Impedance Detection, Residual Current Detection -Surge protection level: TYPE II(DC), TYPE II(AC)

Grid Regulation IEC 61727, IEC 62116, CEI 0-21, EN 50549, NRS 097, RD 140, UNE 217002, OVE-Richtlinie R25, G98, G99, VDE-AR-N 4105

Safety EMC / Standard IEC/EN 61000-6-1/2/3/4, IEC/EN 62109-1, IEC/EN 62109-2



Single Phase Low Voltage Energy Storage Inverters

8kW



Model No: **S6-EHIP8K-L-PLUS**
SKU Code: **12291**

INPUT DC (PV SIDE)

Recommended max. PV array size	16 kW
Max. usable PV input power	12.8 kW
Max. input voltage	500 V
Rated voltage	330 V
Start-up voltage	90 V
MPPT voltage range	90-435 V
Max. input current	32 A / 32 A
Max. short circuit current	40 A / 40 A
MPPT number/Max. input strings number	2/4

INPUT AC (GRID SIDE)

Input voltage range	187-253 V
Max. input current	50 A
Frequency range	45-55 Hz / 55-65 Hz

OUTPUT AC (GRID SIDE)

Rated output power	8 kW
Max. apparent output power	8 kVA
Operation phase	L/N/PE
Rated grid voltage	220 V / 230 V
Rated grid frequency	50 Hz / 60 Hz
Rated grid output current	36.4 A / 34.8 A
Max. output current	36.4 A / 34.8 A
Power factor	>0.99 (0.8 leading - 0.8 lagging)
THDi	<2%

OUTPUT AC (BACK-UP)

Rated output power	8 kW
Max. apparent output power	2 times of rated power, 10 s
Back-up switch time	<4 ms
Rated output voltage	L/N/PE, 220 V / 230 V
Rated frequency	50 Hz / 60 Hz
Rated output current	36.4 A / 34.8 A
Max. AC Passthrough current	50 A
THDv (@linear load)	<2%

BATTERY

Battery type	Li-ion / Lead-acid
Battery voltage range	40-60 V
Max. charge / discharge power	8 kW
Max. charge / discharge current	190 A
Communication	CAN/RS485

FEATURES

DC connection	MC4 plug (PV port) / Terminal Block (BAT port)
AC connection	Terminal Block
Display	LCD + Bluetooth + APP
Communication	RS485, CAN, Optional: Wi-Fi, GPRS, LAN

GENERAL DATA

Dimensions (W*H*D)	335*560*227 mm
Weight	22.2 kg
Topology	High frequency isolation (for battery)
Operating ambient temperature range	-40 ~ +60°C
Ingress protection	IP66
Cooling concept	Intelligent redundant fan-cooling
Max. operation altitude	3000 m
Grid connection standard	NRS 097-2-1, IEC 62116, IEC 61727, IEC 60068, IEC 61683, EN 50530, MEA, PEA, NBR 16149, NBR 16150
Safety/EMC standard	IEC/EN 62109-1/-2, EN 61000-6-2/-3

EFFICIENCY

Max. efficiency	96.2%
EU efficiency	96.1%
BAT charged by PV/AC Max. efficiency	95.3%/93.9%
BAT discharged to AC Max. efficiency	93.8%

PROTECTION

Ground fault monitoring: Yes, DC reverse-polarity protection Yes,
Integrated AFCI 2.0: (Optional), Protection class/Over voltage category: I / II (PV and BAT), III (MAINS and BACKUP and GEN)

Single Phase Hybrid Solar Inverter



NEW

10 YEAR WARRANTY

Model No: **SUN-8K-SG05LP1-EU-AM2-P**
SKU Code: **12310**

8kW

AC INPUT/OUTPUT DATA

Rated AC Input/Output Active Power (W)	8000
Max. AC Input/Output Apparent Power (VA)	8800
Rated AC Input/Output Current (A)	36.4/34.8
Max. AC Input/Output Current (A)	40/38.3
Max. Continuous AC Passthrough (grid to load) (A)	50
Peak Power (off-grid) (W)	2 times of rated power, 10s
Power Factor Adjustment Range	0.8 leading to 0.8 lagging
Rated Input/Output Voltage/Range (V)	220/230 0.85Un-1.1Un
Rated Input/Output Grid Frequency/Range(Hz)	50/45-55, 60/55-65
Grid Connection Form	L+N+PE
Total Current Harmonic Distortion THDi	<3% (of nominal power)
DC Injection Current	<0.5% In

PV STRING INPUT DATA

Max. PV Access Power (W)	16000
Max. PV Input Power (W)	12800
Max. PV Input Voltage (V)	500
Start-up Voltage (V)	125
MPPT Voltage Range (V)	150-425
Rated PV Input Voltage (V)	370
Max. Operating PV Input Current (A)	32+32
Max. Input Short-Circuit Current (A)	48+48
No. of MPP Trackers/ No. of Strings MPP Tracker	2/2+2

GENERAL DATA

Operating Temperature Range ()	-40 to +60°C, >45° C Derating
Permissible Ambient Humidity	0-100%
Permissible Altitude	2000m
Noise (dB)	<30
Ingress Protection(IP) Rating	IP 65
Inverter Topology	Non-Isolated
Over Voltage Category	OVC II(DC), OVC III(AC)
Cabinet Size (WxHxD mm)	330×580×232
Weight (kg)	24.9
Type of Cooling	Intelligent Air Cooling

BATTERY PORT

Battery Type	Lead-acid or Lithium-ion
Battery Voltage Range (V)	40-60
Max. Charging Current (A)	190
Max. Discharging Current (A)	190
Charging Strategy for Li-ion Battery	Self-adaption to BMS
Number of Battery Input	1

EFFICIENCY

Max. Efficiency	97.6%
Euro Efficiency	96.5%
MPPT Efficiency	>99%

PROTECTION & CERTIFICATIONS

Integrated DC Polarity Reverse Connection Protection, AC Output Overcurrent Protection, Thermal Protection, AC Output Overvoltage Protection, AC Output Short Circuit Protection, DC Component Monitoring, Overvoltage Load Drop Protection, Ground Fault Current Monitoring, Arc Fault Circuit Interrupter (optional), Power Network Monitoring, Island Protection Monitoring, Earth Fault Detection, DC Input Switch, DC Terminal Insulation Impedance Monitoring, Residual Current (RCD) Detection, Surge protection level: TYPE II(DC), TYPE II(AC)

Grid Regulation IEC 61727, IEC 62116, CEI 0-21, EN 50549, NRS 097, RD 140, UNE 217002, OVE-Richtlinie R25, G98, G99, VDE-AR-N 4105

Safety EMC / Standard IEC/EN 61000-6-1/2/3/4, IEC/EN 62109-1, IEC/EN 62109-2



NEW

Single Phase Hybrid Solar Inverter **10kW**

Model No: SUN-10K-SG02LP1-EU-AM3-P
SKU Code: 12680

AC INPUT/OUTPUT DATA

Rated AC Input/Output Active Power (W)	10000
Max. AC Input/Output Apparent Power (VA)	11000
Rated AC Input/Output Current (A)	45.5/43.5
Max. AC Input/Output Current (A)	50/47.9
Max. Continuous AC Passthrough (grid to load) (A)	60
Peak Power (off-grid) (W)	2 times of rated power, 10s
Power Factor Adjustment Range	0.8 leading to 0.8 lagging
Rated Input/Output Voltage/Range (V)	220/230 0.85Un-1.1Un
Rated Input/Output Grid Frequency/Range(Hz)	50/45-55, 60/55-65
Grid Connection Form	L+N+PE
Total Current Harmonic Distortion THDi	<3% (of nominal power)
DC Injection Current	<0.5% In

BATTERY INPUT DATA

Battery Type	Lead-acid or Lithium-ion
Battery Voltage Range (V)	40-60
Max. Charging Current (A)	220
Max. Discharging Current (A)	220
Charging Strategy for Li-ion Battery	Self-adaption to BMS
Number of Battery Input	1

GENERAL DATA

Operating Temperature Range (°C)	-40 to +60°C, >45°C Derating
Permissible Ambient Humidity	0-100%
Permissible Altitude	2000m
Noise (dB)	<45
Ingress Protection(IP) Rating	IP 65
Inverter Topology	Non-Isolated
Over Voltage Category	OVC II(DC), OVC III(AC)
Cabinet Size (WxHxD mm)	420×670×233
Weight (kg)	35.6
Type of Cooling	Intelligent Air Cooling
Warranty	5 Years/10 Years

Grid Regulation

VDE4105, IEC61727/62116, VDE0126, AS4777.2, CEI 0 21, EN50549-1, G98, G99, C10-11, UNE217002, NBR16149/NBR16150

PV STRING INPUT DATA

Max. PV Access Power (W)	20000
Max. PV Input Power (W)	16000
Max. PV Input Voltage (V)	500
Start-up Voltage (V)	125
MPPT Voltage Range (V)	150-425
Rated PV Input Voltage (V)	370
Max. Operating PV Input Current (A)	32+32+32
Max. Input Short-Circuit Current (A)	60+60+60
No. of MPP Trackers/No. of Strings	3/2+2+2
MPP Tracker	

EFFICIENCY

Max. Efficiency	97.6%
Euro Efficiency	96.5%
MPPT Efficiency	>99%

INTERFACE

Communication Interface	RS485/RS232/CAN
Monitor Mode	GPRS/WIFI/Bluetooth/4G/ LAN(optional)

PROTECTION & CERTIFICATIONS

Integrated

DC Reverse Polarity Protection, AC Output Overcurrent Protection, Thermal Protection, AC Output Overvoltage Protection, AC Output Short Circuit Protection, DC Component Monitoring, Arc Fault Circuit Interrupter (optional), Anti-islanding Protection, DC Switch, Insulation Impedance Detection, Residual Current Detection

Surge Protection Level
TYPE II(DC), TYPE II(AC)

Safety / EMC Standard

IEC/EN 61000-6-1/2/3/4, IEC/EN 62109-1, IEC/EN 62109-2



NEW Single Phase Hybrid Solar Inverter
12kW

Model No: SUN-12K-SG02LP1-EU-AM3-P
SKU Code: 12675

AC INPUT/OUTPUT DATA

Rated AC Input/Output Active Power (W)	12000
Max. AC Input/Output Apparent Power (VA)	13200
Rated AC Input/Output Current (A)	54.6/52.2
Max. AC Input/Output Current (A)	60/57.4
Max. Continuous AC Passthrough (grid to load) (A)	60
Peak Power (off-grid) (W)	2 times of rated power, 10s
Power Factor Adjustment Range	0.8 leading to 0.8 lagging
Rated Input/Output Voltage/Range (V)	220/230 0.85Un-1.1Un
Rated Input/Output Grid Frequency/Range(Hz)	50/45-55, 60/55-65
Grid Connection Form	L+N+PE
Total Current Harmonic Distortion THDi	<3% (of nominal power)
DC Injection Current	<0.5% In

BATTERY INPUT DATA

Battery Type	Lead-acid or Lithium-ion
Battery Voltage Range (V)	40-60
Max. Charging Current (A)	250
Max. Discharging Current (A)	250
Charging Strategy for Li-ion Battery	Self-adaption to BMS
Number of Battery Input	1

GENERAL DATA

Operating Temperature Range (°C)	-40 to +60°C, >45°C Derating
Permissible Ambient Humidity	0-100%
Permissible Altitude	2000m
Noise (dB)	<45
Ingress Protection(IP) Rating	IP 65
Inverter Topology	Non-Isolated
Over Voltage Category	OVC II(DC), OVC III(AC)
Cabinet Size (WxHxD mm)	420×670×233
Weight (kg)	35.6
Type of Cooling	Intelligent Air Cooling
Warranty	5 Years/10 Years

Grid Regulation

VDE4105, IEC61727/62116, VDE0126, AS4777.2, CEI 0 21, EN50549-1, G98, G99, C10-11, UNE217002, NBR16149/NBR16150

PV STRING INPUT DATA

Max. PV Access Power (W)	24000
Max. PV Input Power (W)	19200
Max. PV Input Voltage (V)	500
Start-up Voltage (V)	125
MPPT Voltage Range (V)	150-425
Rated PV Input Voltage (V)	370
Max. Operating PV Input Current (A)	32+32+32
Max. Input Short-Circuit Current (A)	60+60+60
No. of MPP Trackers/No. of Strings	3/2+2+2
MPP Tracker	

EFFICIENCY

Max. Efficiency	97.6%
Euro Efficiency	96.5%
MPPT Efficiency	>99%

INTERFACE

Communication Interface	RS485/RS232/CAN
Monitor Mode	GPRS/WIFI/Bluetooth/4G/ LAN(optional)

PROTECTION & CERTIFICATIONS

Integrated

DC Reverse Polarity Protection, AC Output Overcurrent Protection, Thermal Protection, AC Output Overvoltage Protection, AC Output Short Circuit Protection, DC Component Monitoring, Arc Fault Circuit Interrupter (optional), Anti-islanding Protection, DC Switch, Insulation Impedance Detection, Residual Current Detection

Surge Protection Level
TYPE II(DC), TYPE II(AC)

Safety / EMC Standard

IEC/EN 61000-6-1/2/3/4, IEC/EN 62109-1, IEC/EN 62109-2

Single Phase Hybrid Solar Inverter

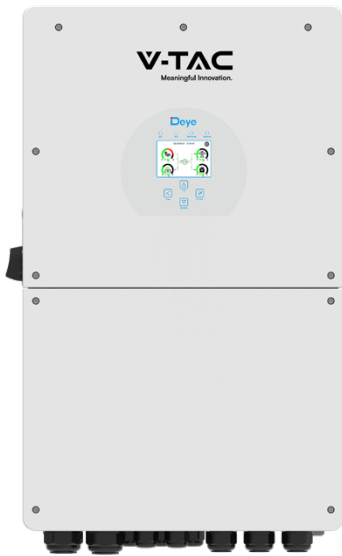

16kW

Model No: **SUN-16K-SG01LP1-EU**
SKU Code: **12159**

AC LOAD OUTPUT

Rated AC Input/Output Active Power (W)	16000
Max. AC Input/Output Apparent Power (VA)	17600
Rated AC Input/Output Current (A)	72.7/69.6
Max. AC Input/Output Current (A)	80/76.5
Max. Continuous AC Passthrough (grid to load) (A)	100
Peak Power (off-grid) (W)	2 times of rated power, 10s
Power Factor Adjustment Range	0.8 leading to 0.8 lagging
Rated Input/Output Voltage/Range (V)	220/230 0.85Un-1.1Un
Rated Input/Output Grid Frequency/Range(Hz)	50/45-55, 60/55-65
Grid Connection Form	L+N+PE
Total Current Harmonic Distortion THDi	<3% (of nominal power)
DC Injection Current	<0.5% In

PV INPUT

Max. PV Input Power (W)	20800
Max. PV Input Voltage (V)	500
Start-up Voltage (V)	125
MPPT Voltage Range (V)	150-425
Rated PV Input Voltage (V)	370
Max. Operating PV Input Current (A)	26+26+26
Max. Input Short-Circuit Current (A)	44+44+44
No. of MPP Trackers	3
No. of Strings per MPP Tracker	2+2+2

GENERAL DATA

Operating Temperature Range (°C)	-40 to +60°C, >45°C Derating
Permissible Ambient Humidity	0-100%
Permissible Altitude	2000m
Noise (dB)	<50
Ingress Protection(IP) Rating	IP 65
Inverter Topology	Non-Isolated
Over Voltage Category	OVC II(DC), OVC III(AC)
Cabinet Size (WxHxD mm)	464×763×282
Weight (kg)	52kg
Type of Cooling	Intelligent Air Cooling

BATTERY PORT

Battery Type	Lead-acid or Lithium
Battery Voltage Range (V)	40-60
Max. Charging Current (A)	290
Max. Discharging Current (A)	290
Charging Strategy for Li-ion Battery	Self-adaption to BMS
Number of Battery Input	2

EFFICIENCY

Max. Efficiency	97.6%
Euro Efficiency	96.5%
MPPT Efficiency	>99%

PROTECTION & CERTIFICATIONS

Integrated	DC Polarity Reverse Connection Protection, AC Output Overcurrent Protection AC Output Overvoltage Protection, AC Output Short Circuit Protection, Thermal Protection DC Terminal Insulation Impedance Monitoring, DC Component Monitoring, Ground Fault Current Monitoring Power Network Monitoring, Island Protection Monitoring, Earth Fault Detection, DC Input Switch Overvoltage Load Drop Protection, Residual Current (RCD) Detection, Surge protection level Surge Protection Level: TYPE II(DC), TYPE II(AC)
Grid Regulation	IEC 61727, IEC 62116, AS 4777.2, NRS 097
Safety EMC / Standard	IEC/EN 61000-6-1/2/3/4, IEC/EN 62109-1, IEC/EN 62109-2
Warranty	10 Years the Warranty Period Depends the Final Installation Site of Inverter, More Info Please Refer to Warranty Policy

Three Phase Hybrid Solar Inverter

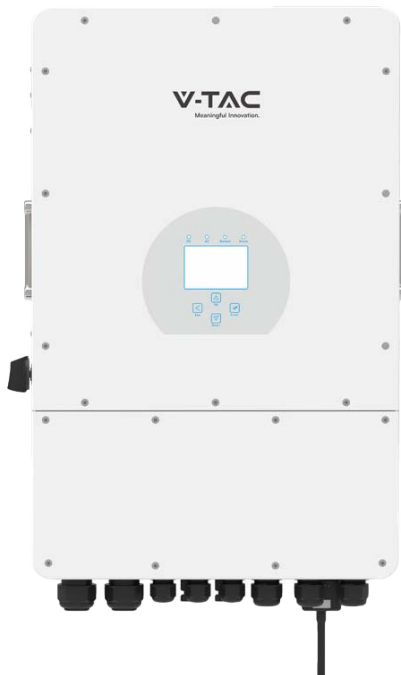

CEI 0-21
CERTIFICATE

10 YEAR
WARRANTY

Model No: **SUN-5K-SG04LP3-EU**
SKU Code: **11743**

5kW

AC LOAD OUTPUT

Rated AC Output Active Power (W)	5000
Max AC Output Active Power (W)	5500
AC Output Rated Current (A)	7.6/7.2
Max AC Output Current (A)	8.4/8
Max. Three-phase Unbalanced Output Current (A)	11.4/10.9
Max Output short circuit current (A)	75
Max. Continuous AC Passthrough (A)	45
Peak Power (off grid)	2 time of rated power, 10 S
Power Factor	0.8 leading to 0.8 lagging
Output Frequency and Voltage	50/60Hz; 3L/N/PE 220/380, 230/400Vac
Grid Type	Three Phase
Total Harmonic Distortion (THD)	<3% (of nominal power)
DC Current Injection	<0.5% In

BATTERY PORT

Battery Type	Lead-acid or Lithium-ion
Battery Voltage Range (V)	40~60
Max. Charging Current (A)	120A
Max. Discharging Current (A)	120A
External Temperature Sensor	Yes
Charging Curve	3 Stages / Equalization
Charging Strategy for Li-Ion Battery	Self-adaption to BMS

PV INPUT

Max. DC Input Power (W)	6500
Rated PV Input Voltage (V)	550 (160-800)
Start-up Voltage (V)	160
MPPT Voltage Range (V)	200-650
Full Load DC Voltage Range (V)	350-650
PV Input Current (A)	13+13
Max. PV ISC (A)	17+17
No.of MPP Trackers	2
No.of Strings per MPP Tracker	1+1

GENERAL DATA

Dimensions (Wx H x D, mm)	422×702×281
Weight (kg)	33.6kg
Operating Temperature Range (°C)	-40~60°C, >45°C derating
Cooling	Smart Cooling
Noise (dB)	≤45 dB
Communication with BMS	RS485; CAN
Protection Degree	IP65
Installation Style	Wall-mounted

EFFICIENCY

Max. Efficiency	97.60%
Euro Efficiency	97.00%
MPPT Efficiency	99.90%

PROTECTION & CERTIFICATIONS

Surge Protection **DC Type III / AC Type III**
Over Voltage Category **DC Type II/AC Type III**

Integrated **Anti-islanding Protection, PV String Input Reverse Polarity Protection, Insulation Resistor Detection, Residual Current Monitoring Unit, Output Over Current Protection, Output Shorted Protection**

Grid Regulation **VDE4105, IEC61727/62116, VDE0126, AS4777.2, CEI 0 21, EN50549-1, G98, G99, C10-11, UNE217002, NBR16149/NBR16150**

Safety EMC / Standard **IEC/EN 61000-6-1/2/3/4, IEC/EN 62109-1, IEC/EN 62109-2**

Three Phase Hybrid Solar Inverter



NEW

10 YEAR WARRANTY

Model No:
SKU Code:

6kW

SUN-6K-SG05LP3-EU-SM2
12345

AC INPUT/OUTPUT DATA

Rated AC Input/Output Active Power (W)	6000
Max. AC Input/Output Apparent Power (VA)	6600
Rated AC Input/Output Current (A)	10/9.6
Max. AC Input/Output Current (A)	9.1/8.7
Max. Continuous AC Passthrough (grid to load) (A)	45
Peak Power (off-grid) (W)	2 times of rated power, 10s
Power Factor Adjustment Range	0.8 leading to 0.8 lagging
Rated Input/Output Voltage/Range (V)	220/230 0.85Un-1.1Un
Rated Input/Output Grid Frequency/Range(Hz)	50/45-55, 60/55-65
Grid Connection Form	3L+N+PE
Total Current Harmonic Distortion THDi	<3% (of nominal power)
DC Injection Current	<0.5% In

PV STRING INPUT DATA

Max. PV Access Power (W)	12000
Max. PV Input Power (W)	9000
Max. PV Input Voltage (V)	800
Start-up Voltage (V)	160
MPPT Voltage Range (V)	200-650
Rated PV Input Voltage (V)	550
Max. Operating PV Input Current (A)	20+20
Max. Input Short-Circuit Current (A)	30+30
No. of MPP Trackers/ No. of Strings MPP Tracker	2/1+1

GENERAL DATA

Operating Temperature Range ()	-40 to +60°C, >45° C Derating
Permissible Ambient Humidity	0-100%
Permissible Altitude	3000m
Noise (dB)	<55
Ingress Protection(IP) Rating	IP 65
Inverter Topology	Non-Isolated
Over Voltage Category	OVC II(DC), OVC III(AC)
Cabinet Size (WxHxD mm)	386×660×250
Weight (kg)	35.2
Type of Cooling	Intelligent Air Cooling

BATTERY PORT

Battery Type	Lead-acid or Lithium-ion
Battery Voltage Range (V)	40-60
Max. Charging Current (A)	135
Max. Discharging Current (A)	135
Charging Strategy for Li-ion Battery	Self-adaption to BMS
Number of Battery Input	1

EFFICIENCY

Max. Efficiency	97.6%
Euro Efficiency	97.0%
MPPT Efficiency	>99%

PROTECTION & CERTIFICATIONS

Integrated DC Polarity Reverse Connection Protection, AC Output Overcurrent Protection, Thermal Protection, AC Output Overvoltage Protection, AC Output Short Circuit Protection, DC Component Monitoring, Overvoltage Load Drop Protection, Ground Fault Current Monitoring, Arc Fault Circuit Interrupter (optional), Power Network Monitoring, Island Protection Monitoring, Earth Fault Detection, DC Input Switch, DC Terminal Insulation Impedance Monitoring, Residual Current (RCD) Detection, Surge protection level, Surge Protection Level: TYPE II(DC), TYPE II(AC)

Grid Regulation IEC 61727, IEC 62116, CEI 0-21, EN 50549, NRS 097, RD 140, UNE 217002, OVE-Richtlinie R25, G98, G99, VDE-AR-N 4105

Safety EMC / Standard IEC/EN 61000-6-1/2/3/4, IEC/EN 62109-1, IEC/EN 62109-2

Three Phase Low Voltage Energy Storage Inverters



NEW

10 YEAR WARRANTY

5KW

8kW

12kW

SUN-5K-SG05LP3-EU-SM2
12654

SUN-8K-SG05LP3-EU-SM2
12643

SUN-12K-SG05LP3-EU-SM2
12655

Ingress Protection(IP) Rating	IP 65
Cabinet Size (WxHxD mm)	386×660×250 (Excluding Connectors and Brackets)
Weight (kg)	35.2

AC INPUT/OUTPUT DATA

Rated AC Input/Output Active Power (W)	5000	8000	12000
Max. AC Input/Output Apparent Power (VA)	5500	8800	13200
Rated AC Input/Output Current (A)	7.6/7.3	12.2/11.6	18.2/17.4
Max. AC Input/Output Current (A)	8.4/8	13.4/12.8	20/19.2
Max. Continuous AC Passthrough (grid to load) (A)	45		
Peak Power (off-grid) (W)	2 times of rated power, 10s		
Power Factor Adjustment Range	0.8 leading to 0.8 lagging		
Rated Input/Output Voltage/Range (V)	220/380V, 230/400V 0.85Un-1.1Un		
Rated Input/Output Grid Frequency/Range(Hz)	50/45-55, 60/55-65		
Grid Connection Form	3L+N+PE		
Total Current Harmonic Distortion THDi	<3% (of nominal power)		
DC Injection Current	<0.5% In		

PV STRING INPUT DATA

Max. PV Access Power (W)	10000	16000	24000
Max. PV Input Power (W)	8000	12800	19200
Max. PV Input Voltage (V)	800	800	800
Start-up Voltage (V)	160	160	160
MPPT Voltage Range (V)	200-650	200-650	200-650
Rated PV Input Voltage (V)	550	550	550
Max. Operating PV Input Current (A)	20+20	20+20	26+26
Max. Input Short-Circuit Current (A)	30+30	30+30	39+39
No. of MPP Trackers/ No. of Strings MPP Tracker	2/1+1	2/1+1	2/2+2

BATTERY PARAMETER

Battery Type	Lead-acid or Lithium-ion		
Battery Voltage Range (V)	40-60		
Max. Charging Current (A)	120	190	240
Max. Discharging Current (A)	120	190	240
Charging Strategy for Li-ion Battery	Self-adaption to BMS		
Number of Battery Input	1		

PROTECTION & CERTIFICATIONS

Integrated DC Reverse Polarity Protection, AC Output Overcurrent Protection, Thermal Protection, AC Output Overvoltage Protection, AC Output Short Circuit Protection, DC Component Monitoring, Arc Fault Circuit Interrupter (optional), Anti-islanding Protection, DC Switch, Insulation Impedance Detection, Residual Current Detection
Surge protection level: TYPE II(DC), TYPE II(AC)

Grid Regulation IEC 61727, IEC 62116, CEI 0-21, EN 50549, NRS 097, RD 140, UNE 217002, OVE-Richtlinie R25, G99, VDE-AR-N 4105

Safety / EMC Standard IEC/EN 61000-6-1/2/3/4, IEC/EN 62109-1, IEC/EN 62109-2

Three Phase Hybrid Solar Inverter



NEW

10 YEAR WARRANTY

10kW

Model No: **SUN-10K-SG05LP3-EU-SM2**
SKU Code: **12343**

AC INPUT/OUTPUT DATA

Rated AC Input/Output Active Power (W)	10000
Max. AC Input/Output Apparent Power (VA)	11000
Rated AC Input/Output Current (A)	15.2/14.5
Max. AC Input/Output Current (A)	16.7/16
Max. Continuous AC Passthrough (grid to load) (A)	45
Peak Power (off-grid) (W)	2 times of rated power, 10s
Power Factor Adjustment Range	0.8 leading to 0.8 lagging
Rated Input/Output Voltage/Range (V)	220/230 0.85Un-1.1Un
Rated Input/Output Grid Frequency/Range(Hz)	50/45-55, 60/55-65
Grid Connection Form	3L+N+PE
Total Current Harmonic Distortion THDi	<3% (of nominal power)
DC Injection Current	<0.5% In

PV STRING INPUT DATA

Max. PV Access Power (W)	20000
Max. PV Input Power (W)	15000
Max. PV Input Voltage (V)	800
Start-up Voltage (V)	160
MPPT Voltage Range (V)	200-650
Rated PV Input Voltage (V)	550
Max. Operating PV Input Current (A)	20+20
Max. Input Short-Circuit Current (A)	30+30
No. of MPP Trackers/ No. of Strings MPP Tracker	2/1+1

GENERAL DATA

Operating Temperature Range ()	-40 to +60°C, >45° C Derating
Permissible Ambient Humidity	0-100%
Permissible Altitude	3000m
Noise (dB)	<55
Ingress Protection(IP) Rating	IP 65
Inverter Topology	Non-Isolated
Over Voltage Category	OVC II(DC), OVC III(AC)
Cabinet Size (WxHxD mm)	386×660×250
Weight (kg)	35.2
Type of Cooling	Intelligent Air Cooling

BATTERY PORT

Battery Type	Lead-acid or Lithium-ion
Battery Voltage Range (V)	40-60
Max. Charging Current (A)	210
Max. Discharging Current (A)	210
Charging Strategy for Li-ion Battery	Self-adaption to BMS
Number of Battery Input	1

EFFICIENCY

Max. Efficiency	97.6%
Euro Efficiency	97.0%
MPPT Efficiency	>99%

PROTECTION & CERTIFICATIONS

Integrated DC Polarity Reverse Connection Protection, AC Output Overcurrent Protection, Thermal Protection, AC Output Overvoltage Protection, AC Output Short Circuit Protection, DC Component Monitoring, Overvoltage Load Drop Protection, Ground Fault Current Monitoring, Arc Fault Circuit Interrupter (optional), Power Network Monitoring, Island Protection Monitoring, Earth Fault Detection, DC Input Switch, DC Terminal Insulation Impedance Monitoring, Residual Current (RCD) Detection, Surge protection level, Surge Protection Level: TYPE II(DC), TYPE II(AC)

Grid Regulation IEC 61727, IEC 62116, CEI 0-21, EN 50549, NRS 097, RD 140, UNE 217002, OVE-Richtlinie R25, G98, G99, VDE-AR-N 4105

Safety EMC / Standard IEC/EN 61000-6-1/2/3/4, IEC/EN 62109-1, IEC/EN 62109-2



Three Phase Low Voltage Energy Storage Inverters

10kW

Model No: **S6-EH3P10K02-NV-YD-L**
SKU Code: **12292**



BATTERY

Battery type	Li-ion / Lead-acid
Battery voltage range	40 - 60 V
Max. charge / discharge current	220 A
Communication	CAN / RS485

OUTPUT AC (GRID SIDE)

Rated output power	10 kW
Max. apparent output power	10 kVA
Operation phase	3/N/PE
Rated grid voltage	380 V / 400 V
Rated grid frequency	50 Hz / 60 Hz
Rated grid output current	15.2 A / 14.4 A
Max. output current	15.2 A / 14.4 A
Power factor	> 0.99 (0.8 leading - 0.8 lagging)
THDi	< 3%

GENERAL DATA

Dimensions (W × H × D)	430 × 660 × 295 mm
Weight	42 kg
Topology	Non-isolated
Operating ambient temperature range	-40 ~ +60°C
Ingress protection	IP66
Noise emission (typical)	< 65 dB(A)
Cooling concept	Intelligent fan-cooling
Max. operation altitude	4000 m
Safety / EMC standard	IEC/EN 62109-1/-2, IEC/EN 61000-6-1/-3

INPUT DC (PV SIDE)

Max. usable PV input power	16 kW
Max. input voltage	1000 V
Rated voltage	550 V
Start-up voltage	160 V
MPPT voltage range	200 - 850 V
Max. input current	20 A / 40 A
Max. short circuit current	30 A / 50 A
MPPT number / Max. input strings number	2 / 3

INPUT AC (GRID SIDE)

Input voltage range	323 - 460 V
Max. input current	22.8 A / 21.7 A
Frequency range	45 - 55 Hz / 55 - 65 Hz

INPUT GENERATOR

Max. input power	10 kW
Max. input current	15.2 A
Rated input voltage	3/N/PE, 380 V / 400 V
Rated input frequency	50 Hz / 60 Hz

OUTPUT AC (BACK-UP)

Rated output power	10 kW
Max. apparent output power	2 times of rated power, 10 s
Back-up switch time	< 10 ms
Rated output voltage	3/N/PE, 380 V / 400 V
Rated frequency	50 Hz / 60 Hz
Rated output current	15.2 A / 14.4 A
Max. continuous output current	15.2 A
Max. continuous AC passthrough current	50 A
THDv (@linear load)	< 3%

EFFICIENCY

Max. efficiency	97.6%
EU efficiency	97.0%

FEATURES

DC connection	MC4 Quick connection plug (PV) & Screw terminal (Battery)
AC connection	Screw terminal
Display	7.0" LCD display & Bluetooth + APP
Communication	CAN, RS485, Ethernet, Optional: Wi-Fi, Cellular, LAN

Grid connection standard
NRS 097-2-1, IEC 62116, IEC 61727, IEC 60068, IEC 61683, EN 50530, SriLanka, EN 50438L, Vietnam, PEA\MEA

PROTECTION

Anti-islanding protection, Output over current protection, Short circuit protection, DC reverse-polarity protection, Surge protection



Three Phase Low Voltage Energy Storage Inverters

12kW

10
YEAR
WARRANTY

Model No: **S6-EH3P12K02-NV-YD-L**
SKU Code: **12228**

BATTERY

Battery type	Li-ion / Lead-acid
Battery voltage range	40 - 60 V
Max. charge / discharge current	250 A
Communication	CAN / RS485

OUTPUT AC (GRID SIDE)

Rated output power	12 kW
Max. apparent output power	12 kVA
Operation phase	3/N/PE
Rated grid voltage	380 V / 400 V
Rated grid frequency	50 Hz / 60 Hz
Rated grid output current	18.2 A / 17.3 A
Max. output current	18.2 A / 17.3 A
Power factor	> 0.99 (0.8 leading - 0.8 lagging)
THDi	< 3%

GENERAL DATA

Dimensions (W × H × D)	430 × 660 × 295 mm
Weight	42 kg
Topology	Non-isolated
Operating ambient temperature range	-40 ~ +60°C
Ingress protection	IP66
Noise emission (typical)	< 65 dB(A)
Cooling concept	Intelligent fan-cooling
Max. operation altitude	4000 m
Safety / EMC standard	IEC/EN 62109-1/-2, IEC/EN 61000-6-1/-3

PROTECTION

Anti-islanding protection, Output over current protection, Short circuit protection, DC reverse-polarity protection, Surge protection

INPUT DC (PV SIDE)

Max. usable PV input power	19.2 kW
Max. input voltage	1000 V
Rated voltage	550 V
Start-up voltage	160 V
MPPT voltage range	200 - 850 V
Max. input current	20 A / 40 A
Max. short circuit current	30 A / 50 A
MPPT number / Max. input strings number	2 / 3

INPUT AC (GRID SIDE)

Input voltage range	323 - 460 V
Max. input current	27.3 A / 26.0 A
Frequency range	45 - 55 Hz / 55 - 65 Hz

INPUT GENERATOR

Max. input power	12 kW
Max. input current	18.2 A
Rated input voltage	3/N/PE, 380 V / 400 V
Rated input frequency	50 Hz / 60 Hz

OUTPUT AC (BACK-UP)

Rated output power	12 kW
Max. apparent output power	2 times of rated power, 10 s
Back-up switch time	< 10 ms
Rated output voltage	3/N/PE, 380 V / 400 V
Rated frequency	50 Hz / 60 Hz
Rated output current	18.2 A / 17.3 A
Max. continuous output current	18.2 A
Max. continuous AC passthrough current	50 A
THDv (@linear load)	< 3%

EFFICIENCY

Max. efficiency	97.6%
EU efficiency	97.0%

FEATURES

DC connection	MC4 Quick connection plug (PV) & Screw terminal (Battery)
AC connection	Screw terminal
Display	7.0" LCD display & Bluetooth + APP
Communication	CAN, RS485, Ethernet, Optional: Wi-Fi, Cellular, LAN

Grid connection standard
NRS 097-2-1, IEC 62116, IEC 61727, IEC 60068, IEC 61683, EN 50530, SriLanka, EN 50438L, Vietnam, PEAMEA

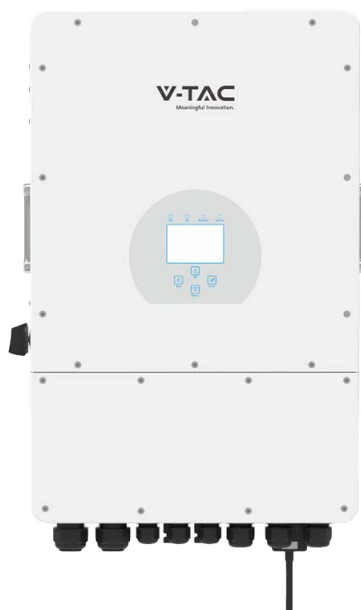

Three Phase Hybrid Solar Inverter

CEI 0-21
CERTIFICATE

10 YEAR
WARRANTY

12kW

Model No: SUN-12K-SG04LP3-EU
SKU Code: 11543

AC LOAD OUTPUT

Rated AC Output Active Power (W)	12000
Max AC Output Active Power (W)	13200
AC Output Rated Current (A)	18.2/17.4
Max AC Output Current (A)	20/19.1
Max. Three-phase Unbalanced Output Current (A)	27.3/26.1
Max Output short circuit current (A)	75
Max. Continuous AC Passthrough (A)	45
Peak Power (off grid)	2 time of rated power, 10 S
Power Factor	0.8 leading to 0.8 lagging
Output Frequency and Voltage	50/60Hz; 3L/N/PE 220/380, 230/400Vac
Grid Type	Three Phase
Total Harmonic Distortion (THD)	<3% (of nominal power)
DC Current Injection	<0.5% In

BATTERY PORT

Battery Type	Lead-acid or Lithium-ion
Battery Voltage Range (V)	40~60
Max. Charging Current (A)	240A
Max. Discharging Current (A)	240A
External Temperature Sensor	Yes
Charging Curve	3 Stages / Equalization
Charging Strategy for Li-Ion Battery	Self-adaption to BMS

PV INPUT

Max. DC Input Power (W)	15600
Rated PV Input Voltage (V)	550 (160-800)
Start-up Voltage (V)	160
MPPT Voltage Range (V)	200-650
Full Load DC Voltage Range (V)	350-650
PV Input Current (A)	26+13
Max. PV ISC (A)	34+17
No.of MPP Trackers	2
No.of Strings per MPP Tracker	2 +1

GENERAL DATA

Dimensions (Wx H x D, mm)	422×702×281
Weight (kg)	33.6kg
Operating Temperature Range (°C)	-40~60°C, >45°C derating
Cooling	Smart Cooling
Noise (dB)	≤45 dB
Communication with BMS	RS485; CAN
Protection Degree	IP65
Installation Style	Wall-mounted

PROTECTION & CERTIFICATIONS

Surge Protection DC Type III / AC Type III
Over Voltage Category DC Type II/AC Type III

Integrated Anti-islanding Protection, PV String Input Reverse Polarity Protection, Insulation Resistor Detection, Residual Current Monitoring Unit, Output Over Current Protection, Output Shorted Protection

Grid Regulation VDE4105, IEC61727/62116, VDE0126, AS4777.2, CEI 0 21, EN50549-1, G98, G99, C10-11, UNE217002, NBR16149/NBR16150

Safety EMC / Standard IEC/EN 61000-6-1/2/3/4, IEC/EN 62109-1, IEC/EN 62109-2



Three Phase Low Voltage Energy Storage Inverters

15kW

Model No: **S6-EH3P15K02-NV-YD-L**
SKU Code: **12229**



BATTERY

Battery type	Li-ion / Lead-acid
Battery voltage range	40 - 60 V
Max. charge / discharge current	290 A
Communication	CAN / RS485

OUTPUT AC (GRID SIDE)

Rated output power	15 kW
Max. apparent output power	15 kVA
Operation phase	3/N/PE
Rated grid voltage	380 V / 400 V
Rated grid frequency	50 Hz / 60 Hz
Rated grid output current	22.8 A / 21.7 A
Max. output current	22.8 A / 21.7 A
Power factor	> 0.99 (0.8 leading - 0.8 lagging)
THDi	< 3%

GENERAL DATA

Dimensions (W × H × D)	430 × 660 × 295 mm
Weight	42 kg
Topology	Non-isolated
Operating ambient temperature range	-40 ~ +60°C
Ingress protection	IP66
Noise emission (typical)	< 65 dB(A)
Cooling concept	Intelligent fan-cooling
Max. operation altitude	4000 m
Safety / EMC standard	IEC/EN 62109-1/-2, IEC/EN 61000-6-1/-3

PROTECTION

Anti-islanding protection, Output over current protection, Short circuit protection, DC reverse-polarity protection, Surge protection

INPUT DC (PV SIDE)

Max. usable PV input power	24 kW
Max. input voltage	1000 V
Rated voltage	550 V
Start-up voltage	160 V
MPPT voltage range	200 - 850 V
Max. input current	40 A / 40 A
Max. short circuit current	50 A / 50 A
MPPT number / Max. input strings number	2 / 4

INPUT AC (GRID SIDE)

Input voltage range	323 - 460 V
Max. input current	34.2 A / 32.5 A
Frequency range	45 - 55 Hz / 55 - 65 Hz

INPUT GENERATOR

Max. input power	15 kW
Max. input current	22.8 A
Rated input voltage	3/N/PE, 380 V / 400 V
Rated input frequency	50 Hz / 60 Hz

OUTPUT AC (BACK-UP)

Rated output power	15 kW
Max. apparent output power	2 times of rated power, 10 s
Back-up switch time	< 10 ms
Rated output voltage	3/N/PE, 380 V / 400 V
Rated frequency	50 Hz / 60 Hz
Rated output current	22.8 A / 21.7 A
Max. continuous output current	22.8 A
Max. continuous AC passthrough current	50 A
THDv (@linear load)	< 3%

EFFICIENCY

Max. efficiency	97.6%
EU efficiency	97.0%

FEATURES

DC connection	MC4 Quick connection plug (PV) & Screw terminal (Battery)
AC connection	Screw terminal
Display	7.0" LCD display & Bluetooth + APP
Communication	CAN, RS485, Ethernet, Optional: Wi-Fi, Cellular, LAN

Grid connection standard
NRS 097-2-1, IEC 62116, IEC 61727, IEC 60068, IEC 61683, EN 50530, SriLanka, EN 50438L, Vietnam, PEAMEA



10 YEAR WARRANTY

NEW

Three Phase Hybrid Inverters

10kW

12kW

Model No:	SUN-10K-SG04LP3-EU	SUN-12K-SG04LP3 -EU
SKU Code:	12307	12308
Size WxHxD	422x658x254	422x658x254
Weight (kg)	38	38
IP Rating	IP65	IP65

AC INPUT/OUTPUT DATA

Rated AC Input/Output Active Power (W)	10000	12000
Max. AC Input/Output Apparent Power (VA)	11000	13200
Rated AC Input/Output Current (A)	15.2/14.5	18.2/17.4
Max. AC Input/Output Current (A)	16.7/15.9	20/19.1
Max. Continuous AC Passthrough (grid to load) (A)	45	
Peak Power (off-grid) (W)	2 times of rated power, 10s	
Power Factor Adjustment Range	0.8 leading to 0.8 lagging	
Rated Input/Output Voltage/Range (V)	220/380V, 230/400V 0.85Un-1.1Un	
Rated Input/Output Grid Frequency/Range(Hz)	50/45-55, 60/55-65	
Grid Connection Form	3L+N+PE	
Total Current Harmonic Distortion THDi	<3% (of nominal power)	
DC Injection Current	<0.5% In	

PV STRING INPUT DATA

Max. PV Access Power (W)	20000	24000
Max. PV Input Power (W)	15000	18000
Max. PV Input Voltage (V)	800	
Start-up Voltage (V)	160	
MPPT Voltage Range (V)	200-650	
Rated PV Input Voltage (V)	550	
Max. Operating PV Input Current (A)	26+13	
Max. Input Short-Circuit Current (A)	34+17	
No. of MPP Trackers/No. of Strings MPP Tracker	2/2+1	

BATTERY PARAMETER

Battery Type	Lead-acid or Lithium-ion	
Battery Voltage Range (V)	40-60	
Max. Charging Current (A)	210	240
Max. Discharging Current (A)	210	240
Charging Strategy for Li-ion Battery	Self-adaption to BMS	
Number of Battery Input	1	

PROTECTION & CERTIFICATIONS

Integrated DC Polarity Reverse Connection Protection, AC Output Overcurrent Protection, Thermal Protection, AC Output Overvoltage Protection, AC Output Short Circuit Protection, DC Component Monitoring, Overvoltage Load Drop Protection, Ground Fault Current Monitoring, Arc Fault Circuit Interrupter (optional), Power Network Monitoring, Island Protection Monitoring, Earth Fault Detection, DC Input Switch, DC Terminal Insulation Impedance Monitoring, Residual Current (RCD) Detection, Surge protection level

Grid Regulation IEC 61727, IEC 62116, CEI 0-21, EN 50549, NRS 097, RD 140, UNE 217002, OVE-Richtlinie R25, G98, G99, VDE-AR-N 4105

Safety / EMC Standard IEC/EN 61000-6-1/2/3/4, IEC/EN 62109-1, IEC/EN 62109-2



NEW

CEI 0-21
CERTIFICATE

Three Phase Hybrid Inverters

10 YEAR WARRANTY

15kW

20kW

Model No:	SUN-15K-SG05LP3-EU-SM2	SUN-20K-SG05LP3-EU-SM2
SKU Code:	12184- White 121841- Black	12185- White
Size WxHxD	456x750x268.5	456x750x268.5
Weight (kg)	50.6	50.6
IP Rating	IP65	IP65

AC INPUT/OUTPUT DATA

Rated AC Input/Output Active Power (W)	15000	20000
Max. AC Input/Output Apparent Power (VA)	15000	20000
Rated AC Input/Output Current (A)	22.8/21.8	30.4/29
Max. AC Input/Output Current (A)	22.8/21.8	30.4/29
Max. Continuous AC Passthrough (grid to load) (A)	70	
Peak Power (off-grid) (W)	2 times of rated power, 10s	
Power Factor Adjustment Range	0.8 leading to 0.8 lagging	
Rated Input/Output Voltage/Range (V)	220/380V, 230/400V 0.85Un-1.1Un	
Rated Input/Output Grid Frequency/Range(Hz)	50/45-55, 60/55-65	
Grid Connection Form	3L+N+PE	
Total Current Harmonic Distortion THDi	<3% (of nominal power)	
DC Injection Current	<0.5% In	

PV INPUT

Max. PV Input Power (W)	22500	30000
Max. PV Input Voltage (V)	800	800
Start-up Voltage (V)	160	160
MPPT Voltage Range (V)	160-650	160-650
Rated PV Input Voltage (V)	550	550
Max. Operating PV Input Current (A)	36+20	36+20
Max. Input Short-Circuit Current (A)	54+30	54+30
No. of MPP Trackers/ No. of Strings per MPP Tracker	2/2+2	2/2+2

BATTERY PARAMETER

Battery Type	Lead-acid or Lithium-ion	Lead-acid or Lithium-ion
Battery Voltage Range (V)	40-60	40-60
Max. Charging Current (A)	280	350
Max. Discharging Current (A)	280	350
Charging Strategy for Li-ion Battery	Self-adaption to BMS	Self-adaption to BMS
Number of Battery Input	1	1

PROTECTION & CERTIFICATIONS

Integrated **DC Polarity Reverse Connection Protection, AC Output Overcurrent Protection, AC Output Overvoltage Protection, AC Output Short Circuit Protection, Thermal Protection, DC Terminal Insulation Impedance Monitoring, DC Component Monitoring, Ground Fault Current Monitoring, Power Network Monitoring, Island Protection Monitoring, Earth Fault Detection, DC Input Switch, Overvoltage Load Drop Protection, Residual Current (RCD) Detection, Surge protection level, Surge Protection Level: TYPE II(DC), TYPE II(AC)**

Grid Regulation **IEC 61727, IEC 62116, CEI 0-21, EN 50549, NRS 097, RD 140, UNE 217002, OVE-Richtlinie R25, G99, VDE-AR-N 4105**
Safety / EMC Standard **IEC/EN 61000-6-1/2/3/4, IEC/EN 62109-1, IEC/EN 62109-2**

Three Phase High Voltage Inverter



NEW

10 YEAR WARRANTY

10kW

Model No: **SUN-10K-SG01HP3-EU-DM2**
SKU Code: **12666**

AC INPUT/OUTPUT DATA

Rated AC Input/Output Active Power (W)	10000
Max. AC Input/Output Apparent Power (VA)	11000
Rated AC Input/Output Current (A)	15.2/14.5
Max. AC Input/Output Current (A)	16.7/16
Max. Continuous AC Passthrough (grid to load) (A)	35
Peak Power (off-grid) (W)	1.5 times of rated power, 10s
Power Factor Adjustment Range	0.8 leading to 0.8 lagging
Rated Input/Output Voltage/Range (V)	220/380V, 230/400V 0.85Un-1.1Un
Rated Input/Output Grid Frequency/Range(Hz)	50/45-55, 60/55-65
Grid Connection Form	3L+N+PE
Total Current Harmonic Distortion THDi	<3% (of nominal power)
DC Injection Current	<0.5% In

BATTERY INPUT DATA

Battery Type	Lithium-ion
Battery Voltage Range (V)	160-700
Max. Charging Current (A)	37
Max. Discharging Current (A)	37
Charging Strategy for Li-ion Battery	Self-adaption to BMS
Number of Battery Input	1

PV STRING INPUT DATA

Max. PV Access Power (W)	20000
Max. PV Input Power (W)	16000
Max. PV Input Voltage (V)	1000
Start-up Voltage (V)	180
MPPT Voltage Range (V)	150-850
Rated PV Input Voltage (V)	600
Max. Operating PV Input Current (A)	18+18
Max. Input Short-Circuit Current (A)	27+27
No. of MPP Trackers/ No. of Strings MPP Tracker	2/1+1

GENERAL DATA

Operating Temperature Range	-40-60°C , >45°C Derating
Cooling	Natural Cooling
Noise (dB)	≤45 dB
Communication Interface	WIFI, RS485, CAN
Weight (kg)	24
Cabinet Size (WxHxD mm)	376×470×244.5
Protection Degree	IP65
Installation Style	Wall-mounted

EFFICIENCY

Max. Efficiency	97.6%
Euro Efficiency	97.0%
MPPT Efficiency	>99%

Over Voltage Category **OVC II(DC), OVC III(AC)**

PROTECTION & CERTIFICATIONS

Integrated **DC Reverse Polarity Protection, AC Output Overcurrent Protection, Thermal Protection, AC Output Overvoltage Protection, AC Output Short Circuit Protection, DC Component Monitoring, Arc Fault Circuit Interrupter (optional), Anti-islanding Protection, DC Switch, Insulation Impedance Detection, Residual Current Detection -Surge protection level: TYPE II(DC), TYPE II(AC)**

Grid Regulation **IEC 61727, IEC 62116, CEI 0-21, EN 50549, NRS 097, RD 140, UNE 217002, OVE-Richtlinie R25, G98, G99, VDE-AR-N 4105**

Safety EMC / Standard **IEC/EN 61000-6-1/2/3/4, IEC/EN 62109-1, IEC/EN 62109-2**



Three Phase High Voltage Energy Storage Inverters



10kW

Model No: **S6-EH3P10K2-H 10KW**
SKU Code: **12224**

INPUT DC (PV SIDE)

Recommended max. PV array size	20 kW
Max. usable PV input power	16 kW
Max. input voltage	1000 V
Rated voltage	600 V
Start-up voltage	160 V
MPPT voltage range	200-850 V
Max. input current	16 A / 16 A
Max. short circuit current	24 A / 24 A
MPPT number/Max. input strings number	2/2

INPUT AC (GRID SIDE)

Max. input power	15 kW
Rated input current	22.8 A
Rated input voltage	3/N/PE, 380 V / 400 V
Rated input frequency	50 Hz / 60 Hz

OUTPUT AC (GRID SIDE)

Rated output power	10 kW
Max. apparent output power	10 kVA
Rated grid voltage	3/N/PE, 380 V / 400 V
Rated grid frequency	50 Hz / 60 Hz
Rated grid output current	15.2 A / 14.4 A
Max. output current	15.2 A / 14.4 A
Power factor	>0.99 (0.8 leading - 0.8 lagging)
THDi	<3%

OUTPUT AC (BACK-UP)

Rated output power	10 kW
Max. apparent output power	16 kVA, 60 sec
Back-up switch time	<10 ms
Rated output voltage	3/N/PE, 380 V / 400 V
Rated frequency	50 Hz / 60 Hz
Rated output current	15.2 A / 14.4 A
THDv (@linear load)	<2%

BATTERY

Battery type	Li-ion
Battery voltage range	120-600 V
Max. charge / discharge power	10 kW
Max. charge / discharge current	50 A
Communication	CAN/RS485

FEATURES

PV connection	MC4 connector
Battery connection	Quick connection plug
AC connection	Quick connection plug
Display	LED + Bluetooth + APP
Communication	CAN, RS485, Optional: Wi-Fi, Cellular, LAN

GENERAL DATA

Dimensions (W*H*D)	600*500*230 mm
Weight	30.2 kg
Topology	Transformerless
Self-consumption (night)	<25 W
Operating ambient temperature range	-25 ~ +60°C
Relative humidity	0-95%
Ingress protection	IP66
Cooling concept	Natural convection
Max. operation altitude	4000 m
Safety/EMC standard	IEC/EN 62109-1/-2, IEC/EN 61000-6-1/-3

EFFICIENCY

Max. efficiency	97.9%
EU efficiency	97.5%
BAT charged by PV/AC Max. efficiency	98.3%
BAT discharged to AC Max. efficiency	97.5%

Grid connection standard

G98 or G99, VDE-AR-N 4105 / VDE V 0124, EN 50549-1, VDE 0126 / UTE C 15/VFR:2019, RD 1699/RD 244 / UNE 206006 / UNE 206007-1, CEI 0-21, C10/11, NRS 097-2-1, TOR, EIFS 2018.2, IEC 62116, IEC 61727, IEC 60068, IEC 61683, EN 50530, MEA, PEA

PROTECTION

Anti-islanding protection, Output over current protection, Short circuit protection, Integrated AFCI 2.0 (Optional), Integrated DC switch, DC reverse-polarity protection, PV over voltage protection, Battery reverse protection



Three Phase High Voltage Energy Storage Inverters



12kW

Model No: **S6-EH3P12K2-H**
SKU Code: **12225**

BATTERY

Battery type	Li-ion
Battery voltage range	120-800 V
Max. charge / discharge power	12 kW
Max. charge / discharge current	50 A
Communication	CAN/RS485

OUTPUT AC (GRID SIDE)

Rated output power	12 kW
Max. apparent output power	12 kVA
Rated grid voltage	3/N/PE, 380 V / 400 V
Rated grid frequency	50 Hz
Rated grid output current	18.2 A / 17.3 A
Max. output current	18.2 A / 17.3 A
Power factor	>0.99 (0.8 leading - 0.8 lagging)
THDi	<3%

GENERAL DATA

Dimensions (W*H*D)	599*546*243 mm
Weight	31 kg
Topology	Transformerless
Self-consumption (night)	<25 W
Operating ambient temperature range	-25 ~ +60°C
Relative humidity	0-95%
Ingress protection	IP66
Cooling concept	Intelligent fan-cooling
Max. operation altitude	2000 m
Safety/EMC standard	IEC/EN 62109-1/-2, IEC/EN 61000-6-1/-3, IEC 61000-2

FEATURES

PV connection	MC4 connector
Battery connection	OT terminal
AC connection	OT terminal
Display	LCD + Bluetooth + APP
Communication	CAN, RS485, Ethernet, Optional: Wi-Fi, Cellular, LAN

Grid connection standard
EN 50549-1, VDE4105 CEI 0-21, CEI 0-16, NC-RFG TypeB, NRS 097-2-1 ED 2.1ED 2.1

PROTECTION

Anti-islanding protection, Output over current protection, Short circuit protection, Integrated AFCI 2.0 (Optional), Integrated DC switch, DC reverse-polarity protection, PV over voltage protection, Battery reverse protection

INPUT DC (PV SIDE)

Recommended max. PV array size	24 kW
Max. usable PV input power	19.2 kW
Max. input voltage	1000 V
Rated voltage	600 V
Start-up voltage	160 V
MPPT voltage range	200-850 V
Max. input current	20 A / 20 A / 20 A / 20 A
Max. short circuit current	30 A / 30 A / 30 A / 30 A
Max. input power per MPPT	9 kW
MPPT number/Max. input strings number	4/4

INPUT AC (GRID SIDE)

Max. input power	18 kW
Rated input current	27.3 A / 26 A
Rated input voltage	3/N/PE, 380 V / 400 V
Rated input frequency	50 Hz

INPUT GENERATOR

Max. input power	12 kW
Max. input current	18.2 A / 17.3 A
Rated input frequency	50 Hz

OUTPUT AC (BACK-UP)

Rated output power	12 kW
Max. apparent output power	2 times of rated power, 10 s
Back-up switch time	<10 ms
Rated output voltage	3/N/PE, 380 V / 400 V
Rated frequency	50 Hz
Rated output current	18.2 A / 17.3 A
THDv (@linear load)	<3%

EFFICIENCY

Max. efficiency	97.7%
EU efficiency	97.5%
BAT charged by PV/AC Max. efficiency	98.5%
BAT discharged to AC Max. efficiency	97.2%



Three Phase High Voltage Energy Storage Inverters



15kW

Model No: **S6-EH3P15K2-H**
SKU Code: **12226**

BATTERY

Battery type	Li-ion
Battery voltage range	120-800 V
Max. charge / discharge power	15 kW
Max. charge / discharge current	50 A
Communication	CAN/RS485

OUTPUT AC (GRID SIDE)

Rated output power	15 kW
Max. apparent output power	15 kVA
Rated grid voltage	3/N/PE, 380 V / 400 V
Rated grid frequency	50 Hz
Rated grid output current	22.8 A / 21.7 A
Max. output current	22.8 A / 21.7 A
Power factor	>0.99 (0.8 leading - 0.8 lagging)
THDi	<3%

GENERAL DATA

Dimensions (W*H*D)	599*546*243 mm
Weight	31 kg
Topology	Transformerless
Self-consumption (night)	<25 W
Operating ambient temperature range	-25 ~ +60°C
Relative humidity	0-95%
Ingress protection	IP66
Cooling concept	Intelligent fan-cooling
Max. operation altitude	2000 m
Safety/EMC standard	IEC/EN 62109-1/-2, IEC/EN 61000-6-1/-3, IEC 61000-2

FEATURES

PV connection	MC4 connector
Battery connection	OT terminal
AC connection	OT terminal
Display	LCD + Bluetooth + APP
Communication	CAN, RS485, Ethernet, Optional: Wi-Fi, Cellular, LAN
Grid connection standard	EN 50549-1, VDE4105 CEI 0-21, CEI 0-16, NC-RFG TypeB, NRS 097-2-1 ED 2.1ED 2.1

PROTECTION

Anti-islanding protection, Output over current protection, Short circuit protection, Integrated AFCI 2.0 (Optional), Integrated DC switch, DC reverse-polarity protection, PV over voltage protection, Battery reverse protection

INPUT DC (PV SIDE)

Recommended max. PV array size	30 kW
Max. usable PV input power	24 kW
Max. input voltage	1000 V
Rated voltage	600 V
Start-up voltage	160 V
MPPT voltage range	200-850 V
Max. input current	20 A / 20 A / 20 A / 20 A
Max. short circuit current	30 A / 30 A / 30 A / 30 A
Max. input power per MPPT	9 kW
MPPT number/Max. input strings number	4/4

INPUT AC (GRID SIDE)

Max. input power	22.5 kW
Rated input current	34.2 A / 32.5 A
Rated input voltage	3/N/PE, 380 V / 400 V
Rated input frequency	50 Hz

INPUT GENERATOR

Max. input power	15 kW
Max. input current	22.8 A / 21.7 A
Rated input frequency	50 Hz

OUTPUT AC (BACK-UP)

Rated output power	15 kW 20 kW
Max. apparent output power	2 times of rated power, 10 s
Back-up switch time	<10 ms
Rated output voltage	3/N/PE, 380 V / 400 V
Rated frequency	50 Hz
Rated output current	22.8 A / 21.7 A 30.4 A / 28.9 A
THDv (@linear load)	<3%

EFFICIENCY

Max. efficiency	97.7%
EU efficiency	97.5%
BAT charged by PV/AC Max. efficiency	98.5%
BAT discharged to AC Max. efficiency	97.2%

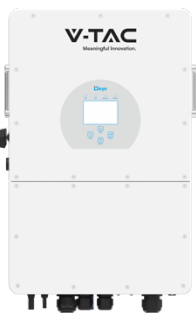

Three Phase Hybrid Inverters

10KW

15kW

20kW

SUN-10K-SG01HP3-EU-AM2
12168

SUN-15K-SG01HP3-EU-AM2
12169

SUN-20K-SG01HP3-EU-AM2
12170

Ingress Protection(IP) Rating	IP 65
Cabinet Size (WxHxD mm)	408×638×237 (Excluding Connectors and Brackets)
Weight (kg)	30.5

AC INPUT/OUTPUT DATA

Rated AC Input/Output Active Power (W)	10000	15000	20000
Max. AC Input/Output Apparent Power (VA)	11000	16500	22000
Rated AC Input/Output Current (A)	15.2/14.5	22.8/21.8	30.4/29
Max. AC Input/Output Current (A)	16.7/16	25/24	33.4/31.9
Max. Three-phase Unbalanced Output Current (A)	22	30	35
Max. Continuous AC Passthrough (grid to load) (A)	40	80	80
Peak Power (o-grid) (W)	1.5 times of rated power, 10s		
Power Factor Adjustment Range	0.8 leading to 0.8 lagging		
Rated Input/Output Voltage/Range (V)	220/380V, 230/400V 0.85Un-1.1Un		
Rated Input/Output Grid Frequency/Range(Hz)	50/45-55, 60/55-65		
Grid Connection Form	3L+N+PE		
Total Current Harmonic Distortion THDi	<3% (of nominal power)		
DC Injection Current	<0.5% In		

PV INPUT

Max. PV Input Power (W)	13000	19500	26000
Max. PV Input Voltage (V)	1000	1000	1000
Start-up Voltage (V)	180	180	180
MPPT Voltage Range (V)	150-850	150-850	150-850
Rated PV Input Voltage (V)	600	600	600
Max. Operating PV Input Current (A)	20+20	26+20	26+26
Max. Input Short-Circuit Current (A)	30+30	39+30	39+39
No. of MPP Trackers/ No. of Strings per MPP Tracker	2/1+1	2/2+1	2/2+2

BATTERY PARAMETER

Battery Type	Lithium-ion
Battery Voltage Range (V)	160-700
Max. Charging Current (A)	37
Max. Discharging Current (A)	37
Charging Strategy for Li-ion Battery	Self-adaption to BMS
Number of Battery Input	1

PROTECTION & CERTIFICATIONS

Protection DC Polarity Reverse Connection Protection, AC Output Overcurrent Protection AC Output Overvoltage Protection, AC Output Short Circuit Protection, Thermal Protection DC Terminal Insulation Impedance Monitoring, DC Component Monitoring, Ground Fault Current Monitoring Power Network Monitoring, Island Protection Monitoring, Earth Fault Detection, DC Input Switch Overvoltage Load Drop Protection, Residual Current (RCD) Detection, Surge protection level: TYPE II(DC), TYPE II(AC)

Grid Regulation IEC 61727, IEC 62116, CEI 0-21, EN 50549, NRS 097, RD 140, UNE 217002, OVE-Richtlinie R25, G99, VDE-AR-N 4105

Safety / EMC Standard IEC/EN 61000-6-1/2/3/4, IEC/EN 62109-1, IEC/EN 62109-2



Three Phase High Voltage Energy Storage Inverters



20kW

Model No: **S6-EH3P20K2-H**
SKU Code: **12227**

BATTERY

Battery type	Li-ion
Battery voltage range	120-800 V
Max. charge / discharge power	20 kW
Max. charge / discharge current	50 A
Communication	CAN/RS485

OUTPUT AC (GRID SIDE)

Rated output power	20 kW
Max. apparent output power	20 kVA
Rated grid voltage	3/N/PE, 380 V / 400 V
Rated grid frequency	50 Hz
Rated grid output current	30.4 A / 28.9 A
Max. output current	30.4 A / 28.9 A
Power factor	>0.99 (0.8 leading - 0.8 lagging)
THDi	<3%

GENERAL DATA

Dimensions (W*H*D)	599*546*243 mm
Weight	31.7 kg
Topology	Transformerless
Self-consumption (night)	<25 W
Operating ambient temperature range	-25 ~ +60°C
Relative humidity	0-95%
Ingress protection	IP66
Cooling concept	Intelligent fan-cooling
Max. operation altitude	2000 m
Safety/EMC standard	IEC/EN 62109-1/-2, IEC/EN 61000-6-1/-3, IEC 61000-2

PROTECTION

Anti-islanding protection, Output over current protection, Short circuit protection, Integrated AFCI 2.0 (Optional), Integrated DC switch, DC reverse-polarity protection, PV over voltage protection, Battery reverse protection

INPUT DC (PV SIDE)

Recommended max. PV array size	40 kW
Max. usable PV input power	32 kW
Max. input voltage	1000 V
Rated voltage	600 V
Start-up voltage	160 V
MPPT voltage range	200-850 V
Max. input current	20 A / 20 A / 20 A / 20 A
Max. short circuit current	30 A / 30 A / 30 A / 30 A
Max. input power per MPPT	9 kW
MPPT number/Max. input strings number	4/4

INPUT AC (GRID SIDE)

Max. input power	30 kW
Rated input current	45.6 A / 43.3 A
Rated input voltage	3/N/PE, 380 V / 400 V
Rated input frequency	50 Hz

INPUT GENERATOR

Max. input power	20 kW
Max. input current	30.4 A / 28.9 A
Rated input frequency	50 Hz

OUTPUT AC (BACK-UP)

Rated output power	20 kW
Max. apparent output power	1.6 time of rated power, 10 s
Back-up switch time	<10 ms
Rated output voltage	3/N/PE, 380 V / 400 V
Rated frequency	50 Hz
Rated output current	30.4 A / 28.9 A
THDv (@linear load)	<3%

EFFICIENCY

Max. efficiency	97.7%
EU efficiency	97.5%
BAT charged by PV/AC Max. efficiency	98.5%
BAT discharged to AC Max. efficiency	97.2%

FEATURES

PV connection	MC4 connector
Battery connection	OT terminal
AC connection	OT terminal
Display	LCD + Bluetooth + APP
Communication	CAN, RS485, Ethernet, Optional: Wi-Fi, Cellular, LAN
Grid connection standard	EN 50549-1, VDE4105 CEI 0-21, CEI 0-16, NC-RFG TypeB, NRS 097-2-1 ED 2.1ED 2.1



Three Phase Energy Storage Inverters



20kW

Model No: **S6-EH3P20K-H**
SKU Code: **12293**

BATTERY

Battery type	Li-ion
Battery voltage range	120 - 800 V
Max. charge / discharge power	20 kW
Max. charge / discharge current	50 A
Communication	CAN / RS485

OUTPUT AC (GRID SIDE)

Rated output power	20 kW
Max. apparent output power	20kVA
Rated grid voltage	3/N/PE, 220 V / 380 V, 230 V / 400 V
Rated grid frequency	50 Hz / 60 Hz
Rated grid output current	30.4 A / 28.9 A
Max. output current	30.4 A / 28.9 A
Power factor	> 0.99 (0.8 leading - 0.8 lagging)
THDi	< 3%

GENERAL DATA

Max. allowable phase imbalance (grid & back-up)	100%
Max. power per phase (grid & back-up)	40% rated power
Dimensions (W × H × D)	563 × 546 × 250 mm
Weight	35.2 kg
Topology	Transformerless
Self-consumption (night)	< 25 W
Operating ambient temperature range	-25 ~ +60°C
Relative humidity	0 - 95%
Ingress protection	IP66
Noise emission (typical)	< 65 dB(A)
Cooling concept	Intelligent fan-cooling
Max. operation altitude	4000 m
Grid connection standard	EN 50549-1/-10, VDE4105, CEI 0-21, CEI 0-16, NC-RFG TypeB, NRS 097-2-1, LTU-1, G99, PEA
Safety / EMC standard	IEC/EN 62109-1/-2, IEC/EN 61000-6-1/-2/-3/-4

INPUT DC (PV SIDE)

Recommended max. PV array size	40 kW
Max. usable PV input power	32 kW
Max. input voltage	1000 V
Rated voltage	600 V
Start-up voltage	160 V
MPPT voltage range	200 - 850 V
Max. input current	4 × 20 A
Max. short circuit current	4 × 30 A
MPPT number / Max. input strings number	4 / 4

INPUT AC (GRID SIDE)

Input voltage range	304 - 437 V / 320 - 460 V
Max. input current	45.6 A / 43.3 A
Rated grid frequency	50 Hz / 60 Hz
Frequency range	45 - 55 Hz / 55 - 65 Hz

INPUT GENERATOR

Max. input power	20 kW
Max. input current	30.4 A / 28.9 A
Rated input frequency	50 Hz / 60 Hz

OUTPUT AC (BACK-UP)

Rated output power	20 kW
Max. apparent output power	1.6 time of rated power, 10 s
Back-up switch time	< 10 ms
Rated output voltage	3/N/PE, 220 / 380, 230 / 400 V
Rated frequency	50 Hz / 60 Hz
Rated output current	30.4 A / 28.9 A
THDv (@linear load)	< 3%

EFFICIENCY

Max. efficiency	97.7%
EU efficiency	97.5%
BAT charged by PV/AC Max. efficiency	98.5%
BAT discharged to AC Max. efficiency	97.2%

FEATURES

PV connection	MC4 connector
Battery connection	OT terminal
AC connection	OT terminal
Display	7.0" LCD display & Bluetooth + APP
Communication	CAN, RS485, Ethernet, Optional: Wi-Fi, Cellular, LAN

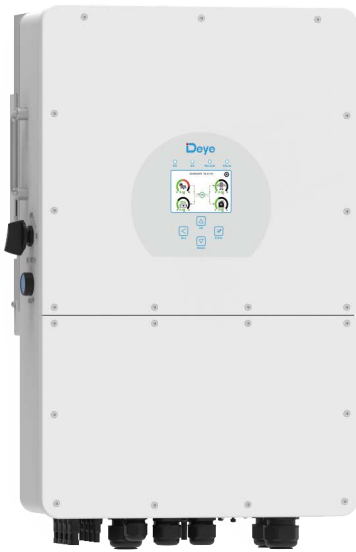

Three Phase High Voltage Inverter



25kW

Model No: **SUN-25K-SG01-HP3-EU-AM2**
SKU Code: **12644**

AC LOAD OUTPUT

Rated AC Input/Output Active Power (W)	25000
Max. AC Input/Output Apparent Power (VA)	27500
Rated AC Input/Output Current (A)	37.9/36.3
Max. AC Input/Output Current (A)	41.7/39.9
Max. Continuous AC Passthrough (grid to load) (A)	80
Peak Power (off-grid) (W)	1.5 times of rated power, 10s
Power Factor Adjustment Range	0.8 leading to 0.8 lagging
Rated Input/Output Voltage/Range (V)	220/380V, 230/400V 0.85Un-1.1Un
Rated Input/Output Grid Frequency/Range(Hz)	50/45-55, 60/55-65
Grid Connection Form	3L+N+PE
Total Current Harmonic Distortion THDi	<3% (of nominal power)
DC Injection Current	<0.5% In

BATTERY INPUT DATA

Battery Type	Lithium-ion
Battery Voltage Range (V)	160-700
Max. Charging Current (A)	50
Max. Discharging Current (A)	50
Charging Strategy for Li-ion Battery	Self-adaption to BMS
Number of Battery Input	1

PV STRING INPUT DATA

Max. PV Access Power (W)	50000
Max. PV Input Power (W)	40000
Max. PV Input Voltage (V)	1000
Start-up Voltage (V)	180
MPPT Voltage Range (V)	150-850
Rated PV Input Voltage (V)	700
Max. Operating PV Input Current (A)	26+26
Max. Input Short-Circuit Current (A)	39+39
No. of MPP Trackers/ No. of Strings MPP Tracker	2/2+2

GENERAL DATA

Operating Temperature Range	-40-60°C , >45°C Derating
Cooling	Intelligent Air Cooling
Noise (dB)	≤55 dB
Communication Interface	RS485/RS232/CAN
Weight (kg)	30.5
Cabinet Size (WxHxD mm)	408×638×237
Protection Degree	IP65
Installation Style	Wall-mounted

EFFICIENCY

Max. Efficiency	97.60%
Euro Efficiency	97.00%
MPPT Efficiency	99%

PROTECTION & CERTIFICATIONS

Over Voltage Category DC Type II/AC Type III

Integrated DC Reverse Polarity Protection, AC Output Overcurrent Protection, Thermal Protection, AC Output Overvoltage Protection, AC Output Short Circuit Protection, DC Component Monitoring, Arc Fault Circuit Interrupter (optional), Anti-islanding Protection, DC Switch, Insulation Impedance Detection, Residual Current Detection -Surge protection level: TYPE II(DC), TYPE II(AC)

Grid Regulation IEC 61727, IEC 62116, CEI 0-21, EN 50549, NRS 097, RD 140, UNE 217002, OVE-Richtlinie R25, G98, G99, VDE-AR-N 4105

Safety EMC / Standard IEC/EN 61000-6-1/2/3/4, IEC/EN 62109-1, IEC/EN 62109-2



Three Phase High Voltage Inverter



30kW

Model No: **SUN-30K-SG02HP3-EU-AM3**
SKU Code: **12674**

AC LOAD OUTPUT

Rated AC Input/Output Active Power (W)	30000
Max. AC Input/Output Apparent Power (VA)	33000
Rated AC Input/Output Current (A)	45.5/43.5
Max. AC Input/Output Current (A)	50/47.9
Max. Continuous AC Passthrough (grid to load) (A)	80
Peak Power (off-grid) (W)	1.5 times of rated power, 10s
Power Factor Adjustment Range	0.8 leading to 0.8 lagging
Rated Input/Output Voltage/Range (V)	220/380V, 230/400V 0.85Un-1.1Un
Rated Input/Output Grid Frequency/Range(Hz)	50/45-55, 60/55-65
Grid Connection Form	3L+N+PE
Total Current Harmonic Distortion THDi	<3% (of nominal power)
DC Injection Current	<0.5% In

BATTERY INPUT DATA

Battery Type	Lithium-ion
Battery Voltage Range (V)	160-700
Max. Charging Current (A)	75
Max. Discharging Current (A)	75
Charging Strategy for Li-ion Battery	Self-adaption to BMS
Number of Battery Input	1

PV STRING INPUT DATA

Max. PV Access Power (W)	60000
Max. PV Input Power (W)	48000
Max. PV Input Voltage (V)	1000
Start-up Voltage (V)	180
MPPT Voltage Range (V)	150-850
Rated PV Input Voltage (V)	600
Max. Operating PV Input Current (A)	36+36+36
Max. Input Short-Circuit Current (A)	54+54+54
No. of MPP Trackers/ No. of Strings MPP Tracker	3/2+2+2

GENERAL DATA

Operating Temperature Range	-40-60°C , >45°C Derating
Cooling	Intelligent Air Cooling
Noise (dB)	≤55 dB
Communication Interface	RS485/RS232/CAN
Weight (kg)	46
Cabinet Size (WxHxD mm)	448x688x 27
Protection Degree	IP65
Installation Style	Wall-mounted

EFFICIENCY

Max. Efficiency	98.50%
Euro Efficiency	98.0%
MPPT Efficiency	>99%

Over Voltage Category DC Type II/AC Type III

PROTECTION & CERTIFICATIONS

Integrated DC Reverse Polarity Protection, AC Output Overcurrent Protection, Thermal Protection, AC Output Overvoltage Protection, AC Output Short Circuit Protection, DC Component Monitoring, Arc Fault Circuit Interrupter (optional), Anti-islanding Protection, DC Switch, Insulation Impedance Detection, Residual Current Detection -Surge protection level: TYPE II(DC), TYPE II(AC)

Grid Regulation IEC 61727, IEC 62116, CEI 0-21, EN 50549, NRS 097, RD 140, UNE 217002, OVE-Richtlinie R25, G98, G99, VDE-AR-N 4105

Safety EMC / Standard IEC/EN 61000-6-1/2/3/4, IEC/EN 62109-1, IEC/EN 62109-2



Three Phase High Voltage Inverter



40kW

Model No: **SUN-40K-SG01HP3-EU-BM4**
SKU Code: **12300**

AC LOAD OUTPUT

Rated AC Output Active Power (W)	40000
Max. AC Output Active Power (W)	44000
AC Output Rated Current (A)	60.7/58
Max. AC Output Current (A)	66.7/63.8
Max. Three-phase Unbalanced Output Current (A)	70
Max. Continuous AC Passthrough (A)	200
Peak Power (Off Grid)	1.5 time of rated power, 10 S
Generator Input/Smart Load /AC Couple Current	60.7 / 200 / 60.7
Power Factor Adjustment Range	0.8 leading to 0.8 lagging
Output Frequency and Voltage	50/60Hz; 3L/N/PE 220/380, 230/400Vac
Grid Type	Three Phase
Total Harmonics Current Distortion (THDi)	<3% (of nominal power)
DC Current Injection	<0.5% In

BATTERY INPUT DATA

Battery Type	Lithium-ion
Battery Voltage Range (V)	160-800
Max. Charging Current (A)	2
Max. Discharging Current (A)	50+50
Number of Battery Input	50+50
Charging Strategy for Li-Ion Battery	Self-adaption to BMS

PV STRING INPUT DATA

Max. DC Input Power (W)	52000
Max. DC Input Voltage (V)	1000
Start-up Voltage (V)	180
MPPT Range (V)	150-850
Rated DC Input Voltage (V)	420-850
Full Load DC Voltage Range (V)	600
PV Input Current (A)	36+36+36+36
Max. PV ISC (A)	55+55+55+55
No.of MPP Trackers	4
No.of Strings per MPP Tracker	2+2+2+2

GENERAL DATA

Operating Temperature Range	-40-60°C , >45°C Derating
Cooling	Smart Cooling
Noise (dB)	≤65 dB
Communication with BMS	CAN
Weight (kg)	80
Cabinet Size (WxHxD mm)	527×894×294
Protection Degree	IP65
Installation Style	Wall-mounted

EFFICIENCY

Max. Efficiency	97.60%
Euro Efficiency	97.00%
MPPT Efficiency	99.90%

Over Voltage Category DC Type II/AC Type III

PROTECTION & CERTIFICATIONS

Integrated Anti-islanding Protection, PV String Input Reverse Polarity Protection, Insulation Resistor Detection, Residual Current Monitoring Unit, Output Over Current Protection, Output Shorted Protection, Surge Protection, Arc Fault Circuit Interruption (AFCI optional)

Grid Regulation IEC 61727, IEC 62116, CEI 0-21, EN 50549, NRS 097, RD 140, UNE 217002, OVE-Richtlinie R25, G99, VDE-AR-N 4105

Safety EMC / Standard IEC/EN 61000-6-1/2/3/4, IEC/EN 62109-1, IEC/EN 62109-2



Three Phase High Voltage Energy Storage Inverters



50kW

Model No: **S6-EH3P50K-H**
SKU Code: **12294**

BATTERY

Battery type	Li-ion
Battery voltage range	150 - 800 V
Max. charge / discharge power	55 kW
Max. charge / discharge current	70 A × 2 ⁽¹⁾
No. of battery inputs	2
Max. charge / discharge power of each input	35 kW
Communication	CAN / RS485

OUTPUT AC (GRID SIDE)

Rated output power	50 kW
Max. apparent output power	50 kVA
Rated grid voltage	3/N/PE, 220 V / 380 V; 3/N/PE, 230 V / 400 V
Rated grid frequency	50 Hz / 60 Hz
Rated grid output current	76 A / 72.2 A
Max. output current	76 A / 72.2 A
Power factor	> 0.99 (0.8 leading - 0.8 lagging)
THDi	< 3%

GENERAL DATA

Dimensions (W*H*D)	530 × 880 × 290 mm
Weight	73 kg
Topology	Transformerless
Self-consumption (night)	< 35 W
Operating ambient temperature range	-25 ~ +60°C
Relative humidity	0 - 95%
Ingress protection	IP66
Cooling concept	Intelligent fan-cooling
Max. operation altitude	4000 m

PROTECTION

Anti-islanding protection, Output over current protection, Short circuit protection, Integrated DC switch, DC reverse-polarity protection, Surge protection: DC Type II / AC Type II, Integrated AFCI 2.0 (Optional)

INPUT DC (PV SIDE)

Recommended max. PV array size	100 kW
Max. usable PV input power	96 kW
Max. input voltage	1000 V
Rated voltage	600 V
Start-up voltage	180 V
MPPT voltage range	150 - 850 V
Max. input current	4 × 40 A
Max. short circuit current	4 × 60 A
MPPT number / Max. input strings number	4 / 8

INPUT AC (GRID SIDE)

Max. AC passthrough current	152 A / 144.4 A
Rated input voltage	3/N/PE, 220 V / 380 V; 3/N/PE, 230 V / 400 V
Rated input frequency	50 Hz / 60 Hz

INPUT GENERATOR

Max. input power	50 kW
Rated input current	76 A / 72.2 A
Rated input voltage	3/N/PE, 220 V / 380 V; 3/N/PE, 230 V / 400 V
Rated input frequency	50 Hz / 60 Hz

OUTPUT AC (BACK-UP)

Rated output power	50 kW
Max. apparent output power	1.6 times of rated power, 2 s
Back-up switch time	< 10 ms
Rated output voltage	3/N/PE, 220 V / 380 V; 3/N/PE, 230 V / 400 V
Rated frequency	50 Hz / 60 Hz
Rated output current	76 A / 72.2 A
THDv (@linear load)	< 2%

EFFICIENCY

Max. efficiency	97.8%
EU efficiency	97.4%
BAT charged by PV/AC Max. efficiency	98.5%
BAT discharged to AC Max. efficiency	97.5%

FEATURES

PV connection	MC4 Quick connection plug
Battery connection	Terminal connector
AC connection	Terminal Block
Display	7.0" LCD display & Bluetooth + APP
Communication	CAN, RS485, Ethernet, Optional: Wi-Fi, Cellular, LAN

Safety / EMC standard
IEC/EN 62109-1/-2, IEC/EN 61000-6-2/-4, EN 55011

Grid connection standard
G99, VDE-AR-N 4105/VDE V 0124, EN 50549-1/EN 50549-10, VDE 0126/UTE C 15/VFR:2019, NTS 631/RD 1699/RD 244/UNE 206006/UNE 206007-1, CEI 0-21, C10/11, NRS 097-2-1, TOR, EIFS 2018.2, IEC 62116, IEC 61727, IEC 60068, IEC 61683, EN 50530, MEA, PEA, PORTARIA No 140, DE 21 DE MARÇO DE 2022

Three Phase Hybrid Solar Inverter

50kW



Model No: SUN-50K-SG01HP3-EU-BM4
SKU Code: 11861

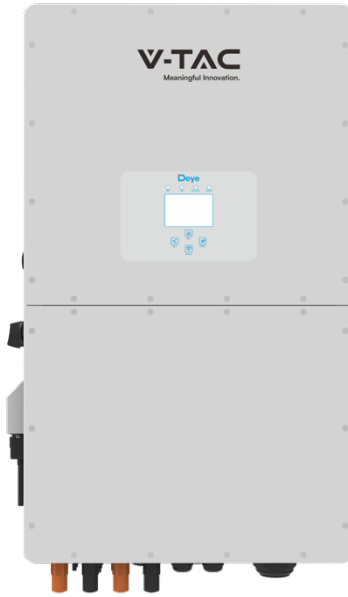

AC LOAD OUTPUT

Rated AC Output Active Power (W)	50000
Max. AC Output Active Power (W)	55000
AC Output Rated Current (A)	75.8/72.5
Max. AC Output Current (A)	83.4/79.7
Max. Three-phase Unbalanced Output Current (A)	83.3
Max. Continuous AC Passthrough (A)	200
Peak Power (Off Grid)	1.5 time of rated power, 10 S
Generator Input/Smart Load /AC Couple Current (A)	75.8 / 200 / 75.8
Power Factor Adjustment Range	0.8 leading to 0.8 lagging
Output Frequency and Voltage	50/60Hz; 3L/N/PE 220/380, 230/400Vac
Grid Type	Three Phase
Total Harmonics Current Distortion (THDi)	<3% (of nominal power)
DC Current Injection	<0.5% In

BATTERY PORT

Battery Type	Lithium-ion
Battery Voltage Range (V)	160-800
Max. Charging Current (A)	50+50
Max. Discharging Current (A)	50+50
Number of Battery Input	2
Charging Strategy for Li-Ion Battery	Self-adaption to BMS

PV INPUT

Max. DC Input Power (W)	65000
Max. DC Input Voltage (V)	1000
Start-up Voltage (V)	180
MPPT Range (V)	150-850
Full Load DC Voltage Range (V)	450-850
Rated DC Input Voltage (V)	600
PV Input Current (A)	36+36+36+36
Max. PV ISC (A)	55+55+55+55
No.of MPP Trackers	4
No.of Strings per MPP Tracker	2+2+2+2

GENERAL DATA

Operating Temperature Range (°C)	-40-60°C, >45°C Derating
Cooling	Smart Cooling
Noise (dB)	≤65 dB
Communication with BMS	CAN
Weight (kg)	80
Protection Degree	IP65
Installation Style	Wall-mounted
Cabinet Size (WxHxD mm)	527×894×294

EFFICIENCY

Max. Efficiency	97.60%
Euro Efficiency	97.00%
MPPT Efficiency	99.90%

PROTECTION & CERTIFICATIONS

Integrated Anti-islanding Protection, PV String Input Reverse Polarity Protection, Insulation Resistor Detection, Residual Current Monitoring Unit, Output Over Current Protection, Output Shorted Protection, Surge Protection, Arc Fault Circuit Interruption (AFCI optional)

Grid Regulation IEC 61727, IEC 62116, CEI 0-21, EN 50549, NRS 097, RD 140, UNE 217002, OVE-Richtlinie R25, G99, VDE-AR-N 4105

Safety EMC / Standard IEC/EN 61000-6-1/2/3/4, IEC/EN 62109-1, IEC/EN 62109-2

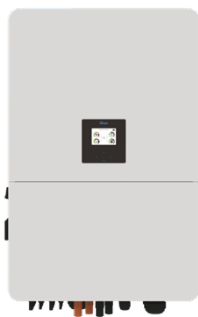

NEW Three Phase Hybrid Solar Inverter

80kW

100kW

125kW

Model No: **SUN-80K-SG02HP3-**
SKU Code: **EU-EM6**
12322

Model No: **SUN-100K-SG02HP3-**
SKU Code: **EU-GM10**
12737

Model No: **SUN-125K-SG02HP3-**
SKU Code: **EU-GM10**
12738

AC LOAD OUTPUT

Rated AC Input/Output Active Power (W)	80000	100000	125000
Max.AC Input/Output Apparent Power (VA)	88000	110000	135000
Rated AC Input/Output Current (A)	121.3/115.9	151.6/145.0	189.4/181.2
Max.AC Input/Output Current (A)	133.4/127.6	166.7/159.5	204.6/195.7
Max.Continuous AC Passthrough (grid to load) (A)	200	250	250
Peak Power (off-grid) (W)	1.5 times of rated power, 10s		
Power Factor Adjustment Range	0.8 leading to 0.8 lagging		
Rated Input/Output Voltage/Range (V)	220/380V, 230/400V 0.85Un-1.1Un		
Rated Input/Output Grid Frequency/Range(Hz)	50/45-55, 60/55-65		
Grid Connection Form	3L+N+PE		
Total Current Harmonic Distortion THDi	<3% (of nominal power)		
DC Injection Current	<0.5% In		

PV INPUT

Max. PV Access Power (W)	160000	200000	250000
Max. PV Input Power (W)	128000	160000	200000
Max. PV Input Voltage (V)	1000	1000	1000
Start-up Voltage (V)	180	180	180
MPPT Voltage Range (V)	150-850	150-850	150-850
Rated PV Input Voltage (V)	650	650	650
Max. Operating PV Input Current (A)	36+36+36+36+36+36	42+42+42+42+42+42+42+42+42+42	42+42+42+42+42+42+42+42+42+42
Max. Input Short-Circuit Current (A)	54+54+54+54+54+54	63+63+63+63+63+63+63+63+63+63	63+63+63+63+63+63+63+63+63+63
No.of MPP Trackers/No.of Strings per MPP Tracker	6/2+2+2+2+2	10/2+2+2+2+2+2+2+2+2+2	10/2+2+2+2+2+2+2+2+2+2

GENERAL DATA

Cabinet Size (WxHxD mm)	606×927×314	606×927×314	606×927×314
General Data	105	105	105
Weight (kg)	Intelligent Air Cooling	Intelligent Air Cooling	Intelligent Air Cooling
Operating Temperature Range°C	-40 to +60°C, >45°C Derating		
Permissible Ambient Humidity	0-100%		
Permissible Altitude	3000m		
Noise (dB)	≤65 dB(A)		
Ingress Protection (IP) Rating	IP 65		
Inverter Topology	Non-Isolated		
Over Voltage Category	OVC II(DC), OVC III(AC)		
Type of Cooling	Smart cooling		
Warranty	10 year		

BATTERY PORT

Battery Type	Lithium-ion		
Battery Voltage Range (V)	160-1000		
Charging Strategy for Li-ion Battery	Self-adaption to BMS		
Number of Battery Input	2		
Max. Charging Current (A)	80+80	100+100	100+100
Max. Discharging Current (A)	80+80	100+100	100+100

EFFICIENCY

Max. Efficiency	98.70%
Euro Efficiency	98.10%
MPPT Efficiency	>99%

PROTECTION & CERTIFICATIONS

Integrated DC Polarity Reverse Connection Protection, AC Output Overcurrent Protection, Thermal Protection, AC Output Overvoltage Protection, AC Output Short Circuit Protection, DC Component Monitoring, Overvoltage Load Drop Protection, Ground Fault Current Monitoring, Arc Fault Circuit Interrupter (optional), Power Network Monitoring, Island Protection Monitoring, Earth Fault Detection, DC Input Switch, DC Terminal Insulation Impedance Monitoring, Residual Current (RCD) Detection, Surge protection level: TYPE II(DC), TYPE II(AC)

Grid Regulation IEC 61727, IEC 62116, CEI 0-21, EN 50549, NRS 097, RD 140, UNE 217002, OVE-Richtlinie R25, G99, VDE-AR-N 4105
Safety EMC / Standard IEC/EN 61000-6-1/2/3/4, IEC/EN 62109-1, IEC/EN 62109-2



NEW
**Three Phase
High Voltage
Energy
Storage
Inverters**

125kW

Model No: **S6-EH3P125K10-NV-YD-H**
SKU Code: **12677**



INPUT DC (PV SIDE)

Recommended max. PV array size	250 kW
Max. usable PV input power	250 kW
Max. input voltage	1000 V
Rated voltage	600 V
Start-up voltage	180 V
MPPT voltage range	150 - 950 V
Max. input current	10 × 42 A
Max. short circuit current	10 × 60 A
MPPT number / Max. input strings number	10 / 20

INPUT AC (GRID SIDE)

Max. input current	250 A
--------------------	-------

OUTPUT AC (GRID SIDE)

Rated output power	125 kW
Max. apparent output power	125 kVA
Rated grid voltage	3/N/PE, 220 V / 380 V, 230 V / 400 V
Rated grid frequency	50 Hz / 60 Hz
Rated grid output current	189.9 A / 180.4 A
Power factor	> 0.99 (0.8 leading - 0.8 lagging)
THDi	< 3%

OUTPUT AC (BACK-UP)

Rated output power	125 kW
Max. apparent output power	1.2 times of rated power, 100 s
	1.4 times of rated power, 10 s
	1.6 times of rated power, 200 ms
Back-up switch time	< 10 ms
Rated output voltage	3/N/PE, 220 V / 380 V, 230 V / 400 V
Rated frequency	50 Hz / 60 Hz
THDv (@linear load)	< 2%

INPUT GENERATOR

Max. input power	125 kW
Rated input current	189.9 A / 180.4 A
Rated input voltage	3/N/PE, 220 V / 380 V; 3/N/PE, 230 V / 400 V
Rated input frequency	50 Hz / 60 Hz

EFFICIENCY

Max. efficiency	97.6%
EU efficiency	97.2%
BAT charged / discharged to AC max.	97.0%

GENERAL DATA

Max. allowable phase imbalance	100%
Max. power per phase (grid & back-up)	41.66 kW
Dimensions (W × H × D)	1174 × 814 × 400 mm
Weight	170 kg
Topology	Transformerless
Operating ambient temperature range	-25 ~ +60°C
Relative humidity	0 - 100%
Ingress protection	IP66
Cooling concept	Intelligent fan-cooling
Max. operation altitude	3000 m

BATTERY

Battery type	Li-ion
Battery voltage range	300 - 950 V
Max. charge / discharge current	200 A / 100 A + 100 A
Number of battery ports	2
Max. charge/discharge current of each port	100 A
Communication	CAN / RS485

FEATURES

PV connection	MC4 Quick connection plug
Battery connection	Terminal connector
AC connection	Terminal Block
Display	7.0" LCD display & Bluetooth + APP
Communication	CAN, RS485, Ethernet, Optional: Wi-Fi, Cellular, LAN

PROTECTION

Safety / EMC standard
IEC/EN 62109-1/-2, IEC/EN 61000-6-2/-4, EN 55011

Anti-islanding protection, Output over current protection, Short circuit protection, Integrated DC switch, DC reverse-polarity protection, Surge protection: DC Type II / AC Type II, Integrated AFCI 2.0 (Optional)

Grid connection standard

G99, VDE-AR-N 4105/VDE V 0124, EN 50549-1&2/EN 50549-10, VDE 0126/UTE C 15/ VFR:2019, NTS 631/RD 1699/RD 244/ UNE 206006/UNE 206007-1, CEI 0-21, C10/11, NRS 097-2-1, TOR, EIFS 2018.2, IEC 62116, IEC 61727, IEC 60068, IEC 61683, EN 50530, MEA, PEA, PORTARIA N° 140, DE 21 DE MARÇO DE 2022;

EV Charger-Single Phase

7.4kW

SKU Code: 11868



Rated Power	7.4kW
Input/Output Voltage	Single-Phase 230V
Input/Output Current	32A
Frequency	50/60Hz
Connector	Type1, Type 2
Cable Length	5m
Authorization	Plug and Charge/NFC/RFID/APP(optional)
Metering	MID Meter
Protection rating	IP65/IK10
Operation altitude	<2000m
RCD	Type A 300mA +DC 6mA
EMC	Class B
Certification	CE/TR25/TUV Mark/RCM/KC/UKCA



TR25



OVER-TEMPERATURE PROTECTION

Intelligent temperature control to prevent high temperature from burning the AC charger.



OVERCURRENT PROTECTION

Protect cables and other components by automatic cut-out from risks of overload and short circuits which cause fire.



SHORT CIRCUIT PROTECTION

The power will be automatically cut off when the vehicle is short circuited to ensure its safety.



BACKFLOW PREVENTION

Automatic power-off protection when the car voltage is higher than the charging pile.



EMERGENCY STOP

In an emergency, you can cut off the power by pressing the emergency stop button simply.



LIGHTING PROTECTION

Deriving current to avoid equipment damage when lighting hits.



OVER/UNDER VOLTAGE PROTECTION

Protects the charging pile when the voltage given by the grid is unstable.



EARTH FAULT PROTECTION

Giving the tripping command to avoid electrical system get short-circuited and ensure safety of users when in the event of an EVSE grounded fault.

PV Module Optimizer

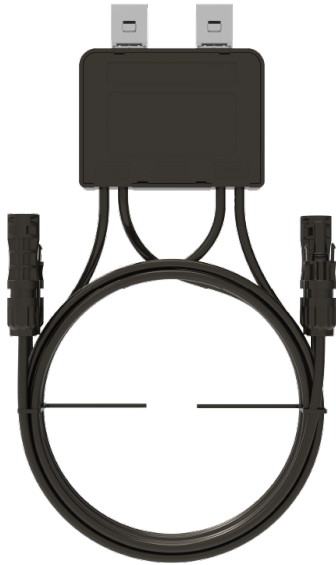

700W

Model No: **SUN-XL02-A**
SKU Code: **11946**

Maximum input power(W)	700W
Maximum input voltage(V)	80V
MPPT voltage range (V)	12-80V
Maximum input current (A)	15A
Peak conversion efficiency	99.5%
Installation specifications dimensions(mm)	105×105×22mm
Weight (g)	600g
Cable	4.0mm ² input 70cm output 100cm
Connector	MC4 Or Compatible with MC4
Operating temperature range	-40°C ~ +85°C
Level of protection	IP68
Product certification	CE

Increase in power generation capacity:

Module-level maximum power point tracking (MPPT) can increase power generation by 5% to 25%.

BATTERY STORAGE SOLUTIONS

V-TAC
Meaningful Innovation.



V-TAC's battery storage solutions offer unparalleled energy independence and efficiency. We provide a diverse range of safe and reliable battery systems tailored to meet various power storage needs, whether for residential or commercial applications.

Our partnerships with top-tier manufacturers ensure that our batteries deliver high performance, longevity, and cutting-edge technology. Designed to seamlessly integrate with solar systems, our battery solutions help you achieve optimal return on investment by maximizing energy usage and minimizing reliance on the grid.



Wall Mounting Batteries

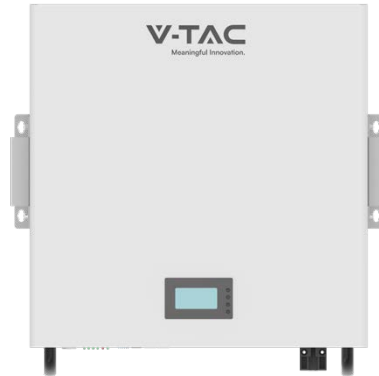

5.12kWh

Model No: VT48100E-W
 SKU Code: 11526
 Net Weight: 43kg
 Size(MM): 443*450*150 mm

GENERAL DATA

Nominal Capacity	100Ah@0.2C, 25
Nominal Voltage	51.2V
Nominal Energy	5.12kWh@0.2C, 25
Charge Voltage	56.8V
Standard Charge Current	20A@25
Max Continuous Charge Current	100A@25
Standard Discharge Current	20A@25
Max Continuous Discharge Current	100A@25
Discharge Cut-off Voltage	42.0V
Operating Temperature	Charge:0~+60°C -Discharge:-20~+60°C
Allowed Humidity Range	≤95% RH
IP	IP20
Cycle Life	25±2°C,0.5C/0.5C,EOL70%≥6000



Self-designed BMS
International design
certification



LifePO4 cells,
ensuring safety of
the battery



Long cyclic life-6000
cycle (80% DOD)



High rate
charge/discharge
current @ 100A



Modular design
Easy expandability

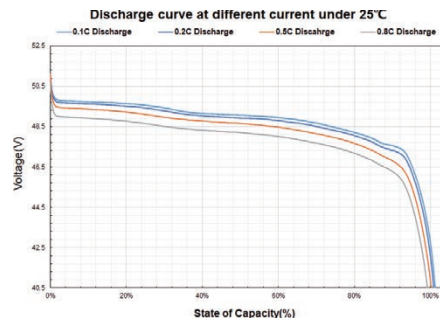
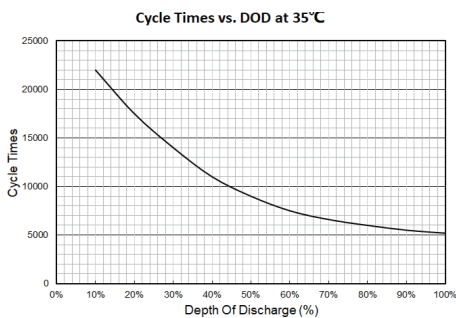

Rack Mounting Lithium Battery

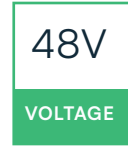
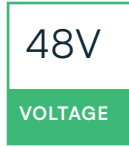
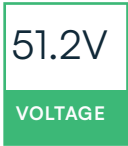

5.12kWh

9.60kWh

9.60kWh

Model No: VT48100E-P2
 SKU Code: 11377
 Net Weight: 41kg
 Size(MM): 440x400x130 mm

Model No: VT-48200B
 SKU Code: 11523
 Net Weight: 78kg
 Size(MM): 442x490x222mm

Model No: VT-91600
 SKU Code: 12684
 Net Weight: 78kg
 Size(MM): 505x490x228mm

GENERAL DATA

Nominal Capacity	100Ah@0.2C, 25°C	200Ah@0.2C, 25°C	200Ah@0.2C, 25°C
Nominal Voltage	51.2V	48.0V	48.0V
Nominal Energy	5.12kWh@0.2C, 25°C	9.60kWh@0.2C, 25°C	9.60kWh@0.2C, 25°C
Charge Voltage	56.8V	54.0V	54.0V
Recommended Charge Current	20A@25°C	20A@25°C	90A@25°C
Max Continuous Charge Current	100A@25°C	100A@25°C	100A@25°C
Recommended Discharge Current	20A@25°C	20A@25°C	90A@25°C
Max Continuous Discharge Current	100A@25°C	100A@25°C	100A@25°C
Discharge Cut-off Voltage	42.0V	40.5V	40.5V
Operating Temperature	Charge:0~+60°C -Discharge:-20~+60°C		
Allowed Humidity Range	≤95% RH		
IP	IP 20		
Cycle Life	25±2°C,0.5C/0.5C,EOL70%≥6000		

STORAGE BATTERY RACK MAX 5 LAYERS



SKU 11556
 Size: 558*500*160mm
 Adapting Battery-
 VT48100E-P2

STORAGE BATTERY RACK MAX 3 LAYERS



SKU 11557
 Size: 598*589*260mm
 Adapting Battery-
 VT48200B



NEW Lithium Ion Batteries
Sleek and Stylish Design

- Quick setup
- Sleek design and stylish batteries
- Compliant with EU grid regulations
- Seamless integration and installation
- Self and cloud monitoring via touch screen and remote application
- Incremental system capacity with paralleling option of inverters and batteries



5.12kWh

10.24kWh

14.33kWh

16.07kWh

Model No: **VT-51200**

SKU Code: **12278-White**

12281-Black

Model No: **VT-10240**

SKU Code: **12279-White**

12282-Black

Model No: **VT-14033**

SKU Code: **12713-White**

Model No: **VT-16076**

SKU Code: **12334-White**

12335-Black

Rated capacity (Ah)	100	200	280	314
Nominal voltage (V)	51.2	51.2	51.2	51.2
Nominal Energy(Kwh)	5.12	10.24	14.33	16.07
Standard Charge Current (A)	90	90	130	140
Standard Discharge Current (A)	90	90	130	140
Maximum continuous charge current (A)	100	100	140	150
Maximum continuous discharge current (A)	100	100	140	150
Communication	CAN	CAN	CAN	CAN
Internal resistance (in Ω)	18m Ω	16m Ω	16m Ω	16m Ω
Dimension(D*W*H)	400*163*710mm	420*237*775mm	660*153.5*900mm	510*242*862mm
Protection Level	IP20	IP20	IP20	IP20
Charge temperature Range (°C)	0 ~ 55	0 ~ 55	0 ~ 55	0 ~ 55
Discharge temperature Range (°C)	-20 ~ 60	-20 ~ 60	-20 ~ 60	-20 ~ 60
Standard Charge Voltage (V)	57.6	57.6	57.6	57.6
Upper limit Charging Voltage (V)	57.6	57.6	57.6	57.6
End-of-discharge Voltage (V)	43.2	43.2	43.2	43.2
Structure	16 series & 1 parallel	16 series & 1 parallel	16 series & 1 parallel	16 series & 1 parallel
Cycle Life	≥6000	≥6000	≥8000	≥7000

Recommend charging method declared by the manufacturer

Charge the battery at constant current 90A until voltage reaches 57.6V, then charge at constant voltage 57.6V till charge current is 10.3A

Charge the battery at constant current 90A until voltage reaches 57.6V, then charge at constant voltage 57.6V till charge current is 10.3A

Charge the battery at constant current 130A until voltage reaches 57.6V, then charge at constant voltage 57.6V till charge current is 15.7A

Charge the battery at constant current 140A until voltage reaches 57.6V, then charge at constant voltage 57.6V till charge current is 15.7A

Wall Mounting Batteries

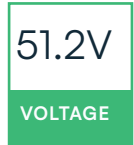
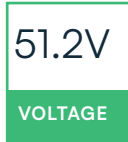

5.12kWh

14.33kWh

Model No: **VE51100W**
 SKU Code: **11524**
 Net Weight: **51.5kg (With Battery Bracket)**
 Size(MM): **410x665x207 (With Battery Bracket)**

Model No: **VE51280W**
 SKU Code: **11525**
 Net Weight: **123.5kg (With Battery Bracket)**
 Size(MM): **607.5x842x261.5 (With Battery Bracket)**

GENERAL DATA

Nominal Voltage (Vdc)	51.2	51.2
Voltage Range (Vdc)	42~57.6V	42~57.6V
Nominal Capacity (kWh)	5.12	14.33
Rated Charge Voltage/@25 °C (Vdc)	57.6V	57.6V
Charge Current/Max. Continuous (A)	100A @25°C	150A @25°C
Discharge Cut-off Voltage/@25 °C (Vdc)	42V	42V
Discharge Current/Max. Continuous (A)	100	200
Communication	CAN/RS-485	
Parallel	15	
Working Temperature/Charge (°C)	0~60°C	
Working Temperature/Discharge (°C)	- 20~60	
Protection Class	IP65	
Cooling Mode	Natural	
Installation Method	Wall-mounted/Floor-Mounted	
Humidity	5% ~ 95%(RH) No Condensation	
Altitude(m)	<2000	
Cycle Life	25±2°C,0.5C/0.5C,80%DOD,EOL70%≥6000	
Deasign Standard	UI1642, IEC62619, EN61000, UN38.3	



NEW

Lithium Battery
SPECIAL LOW TEMPERATURE CELLS



Model No:
SKU Code:

10.24kWh

VT-10242W
12653

14.33kWh

VT-14330
12681

GENERAL DATA

Rated capacity (Ah)	200	280
Nominal voltage (V)	51.2	51.2
Nominal Energy(Kwh)	10.24	14.33
Standard Charge Current (A)	90	140
Standard Discharge Current (A)	90	140
Maximum continuous charge current (A)	100	150
Maximum continuous discharge current (A)	100	150
Communication	CAN	CAN
Internal resistance (in Ω)	16m Ω	18m Ω
Dimension(D*W*H)	460x265x800mm	500*260*842mm
Protection Level	IP65	IP65
Charge temperature Range (°C)	-20 ~55	-20~ 60
Discharge temperature Range(°C)	-20~60	-20 ~ 60
Max Number(s) of battery modules recommended by the manufacturer	15	15
End of Life	≥ 3000@-20 °C EOL 70%	≥ 3000@-20 °C EOL 70%
Cycle Life	≥ 5000@25 °C DOD90%	≥ 5000@25 °C DOD90%
End of Life	≥ 5000@25 °C EOL70%	≥ 5000@25 °C EOL70%
Operating Voltage Range(V)	32V-57.6V	32V-57.6V
End-of-discharge Voltage (V)	40@25 °C	40@25 °C
End-of-discharge Voltage (V)	35.2@-20 °C	35.2@-20 °C
EAN Code	3800170253629	3800170253629

Structure:
16 series & 1 parallel

Recommend charging method declared by the manufacturer:
Charge the battery at constant current 90 A until voltage reaches 57.6V, then charge at constant voltage 57.6V till charge current is 10.3A

Rechargeable Li-ion Battery System

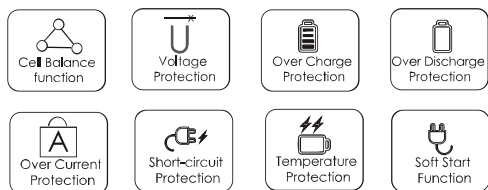

CEI 0-21
CERTIFICATE

10 YEAR
WARRANTY



Compatible with:



Battery:	SKUs:
20.48KW 5.12 x 4	120024
25.6KW 5.12 x 5	120025
30.72KW 5.12 x 6	120026
35.84KW 5.12 x 7	120027
40.96KW 5.12 x 8	120028



Battery Module Qty InSeries(Optional)	4	5	6	7	8
System Nominal Voltage(V)	204.8	256.0	307.2	358.4	409.6
System Nominal Capacity(KWh)	20.48	25.60	30.72	35.84	40.96
Usable Capacity(KWh)	16.38	20.48	24.58	28.67	32.77
Dimension (mm)	590*420*849	590*420*1000	590*420*1151	590*420*1302	590*420*1453
Weight (Kg)	222.4	270.9	319.4	367.9	416.4
Charge/Discharge Current (A)	40				
Communication	CAN				
Altitude	≤2000m				
Cycle Life	25±2°C,0.5C/0.5C,EOL70%≥6000				
Monitoring Parameters	System voltage,Current,cell voltage,cell temperature,module temperature				
SOC	Intelligent algorithm				
Working Temperature	0~35°C				
Storage Temperature	0~35°C				
Installation Mode	Stackable				
Battery Type	LifePO4(LFP)				
Module Energy(kWh)	5.12				
Module Nominal Voltage(V)	51.2				
Module Capacity(Ah)	100				

1. DC Usable Energy, test conditions: 80% DOD, 0.2C charge & discharge at 25°C. System usable energy may vary due to system configuration parameters.
 2. The current is affected by temperature and SOC.
 3. The warranty is due whichever reached first of warranty period or life cycle power.

System Components

HIGH VOLTAGE BATTERY CLUSTER CONTROL BOX

SKU Code: [12151](#)

Operating Voltage	120 750Vdc
Nominal Charge/Discharge Current	40A
Max Charge/Discharge Current	50A
Operating Temperature Range	-10~55°C
Dimension (W/D/H)	590*420*165 mm
Weight Approximate	16.1kg



RECHARGEABLE LI-ION BATTERY MODULE

SKU Code: [12002](#)

Battery Type	LiFePO4(LFP)
Nominal Voltage	51.2Vdc
Rated Capacity	100Ah
Rated Energy	5.12kWh
Nominal Charge/Discharge Current	40A
Peak Discharge Current	50A
Charge Temperature	0~45°C
Discharge Temperature	-10 °C~ 55°C
Storage Temperature	0 °C~ 35°C
Dimension (W/D/H)	590*420*194mm
Weight Approximate	45.6kg

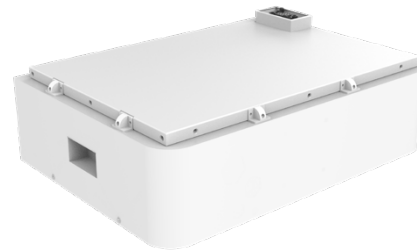

BATTERY MODULE BASE

SKU Code: [12152](#)

Dimension (W/D/H)	590*420*80mm
Weight Approximate	8.5kg

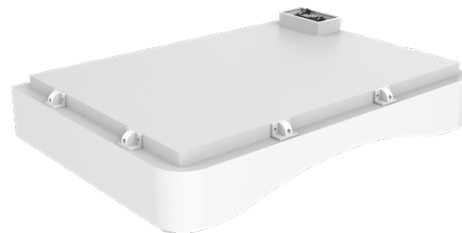

STANDARD 2-METER COMMUNICATION CABLE CONNECTED TO THE EXTERNAL DEVICE



STANDARD 2-METER POWER CABLE CONNECTED TO THE EXTERNAL PCS



NEW

Rechargeable Li-ion Battery System

100kWh

 Model No: OHA-100

 SKU Code: 12676

MAIN PARAMETER

Cell Chemistry	LiFePO4
Module Energy (kWh)	14.33
Module Nominal Voltage (V)	51.2
Module Capacity (Ah)	280Ah
Battery Module Qty In Series (Optional)	7
System Nominal Voltage (V)	358.4
System Operating Voltage (V)	313.6-408.8
System Energy (kWh)	100.35
System Usable Energy (kWh)	90.31
Recommend Charge/Discharge Current (A)	100
Max Charge/Discharge Current (A)	140
Weight Approximate (kg)	~1400
Installation Location	Floor-mounted
Communication	CAN
Ingress Protection	IP65
Altitude	≤2000m
Cycle Life	25±2°C,0.5C/0.5C,EOL70%≥6000
SOC	Intelligent algorithm
Working Temperature	0°C~45°C Charge -10°C ~55°C Discharge
Storage Temperature	0~35°C
Monitoring Parameters	System voltage,Current,cell voltage,cell temperature,module temperature

Dimension (W/D/H,mm) : 985* 1367*2169 (Inverter not included) 1223* 1367*2179 (Inverter included)

HV Battery Set -IP20

105kWh

SKU Code: 12297



- ⦿ 10 pcs - 10.54kW Rechargeable Li-On Battery Module- SKU | 12259
- ⦿ 1 pcs - High Voltage Battery Cluster Control Box- SKU | 12261
- ⦿ 1 pcs - Racks for 10pcs Batteries and 1pc BMS - SKU | 12260

- ⦿ Recommend Charge/Discharge Current 100A
- ⦿ System Nominal Capacity: 105.4kWh (10 x 10.54kWh);
- ⦿ System Usable Capacity:94.8kWh;
- ⦿ System Nominal Voltage: 512V;
- ⦿ System Operating Voltage: 464 - 568V;

IP Rating	IP20
Battery Capacity	206Ah, LiFePO4
Working conditions	Charge: 0~55°C / Discharge: -20°C~+55°C
Size	1200 x 620 x 1870 mm
Item Weight	1029 kg
Cycle Life	25±2°C,0.5C/0.5C,EOL70%≥6000

IP Rating	IP20
Battery Capacity	206Ah, LiFePO4
Working conditions	Charge: 0~55°C / Discharge: -20°C~+55°C
Size	1200 x 620 x 1870 mm
Item Weight	1029 kg
Cycle Life	25±2°C,0.5C/0.5C,EOL70%≥6000



Rechargeable Li-ion Battery System

COMPATIBLE WITH 80KW HYBRID INVERTER

233kWh

SKU Code: 12328



80kW
Inverter

1.SYSTEM EXPANSION

233KWH*2+80KW INVERTER=80KW/466KWH

*Inverter based 2 battery input ports.

Dimension (W/D/H,mm) : 1100* 1400*2105 (Inverter not included) 1600* 1400*2105 (Inverter included)

MAIN PARAMETER

Cell Chemistry	LiFePO4
Module Energy (kWh)	46.59
Module Nominal Voltage (V)	166.4
Module Capacity (Ah)	280Ah
Battery Module Qty In Series (Optional)	5
System Nominal Voltage (V)	832
System Operating Voltage (V)	728~949
System Energy (kWh)	232.96
System Usable Energy (kWh)	209.66
Recommend Charge/Discharge Current (A)	100
Max Charge/Discharge Current (A)	140
Weight Approximate (kg)	~2700
Installation Location	Floor-mounted
Communication	CAN
Ingress Protection	IP65
Altitude	≤2000m
Cycle Life	25±2°C,0.5C/0.5C,EOL70%≥6000
SOC	Intelligent algorithm
Working Temperature	0°C~45°C Charge -10°C ~55°C Discharge
Storage Temperature	0~35°C
Monitoring Parameters	System voltage,Current,cell voltage,cell temperature,module temperature

NEW

Rechargeable Li-ion Battery System

261kWh

COMPATIBLE WITH 80KW HYBRID INVERTER

SKU Code: 12676



1.SYSTEM EXPANSIONV

261KWH*2+80KW INVERTER=80KW/522KWH

*Inverter based 2 battery input ports.

MAIN PARAMETER

Cell Chemistry	LiFePO4
Module Energy (kWh)	52.249
Module Nominal Voltage (V)	166.4
Module Capacity (Ah)	314Ah
Battery Module Qty In Series (Optional)	5
System Nominal Voltage (V)	832
System Operating Voltage (V)	728~949
System Energy (kWh)	261.245
System Usable Energy (kWh)	235.12
Recommend Charge/Discharge Current (A)	100
Max Charge/Discharge Current (A)	157
Weight Approximate (kg)	~2700
Installation Location	Floor-mounted
Communication	CAN
Ingress Protection	IP65
Altitude	≤2000m
Cycle Life	25±2°C,0.5C/0.5C,EOL70%≥6000
SOC	Intelligent algorithm
Working Temperature	0°C~45°C Charge -10°C ~55°C Discharge
Storage Temperature	0~35°C
Monitoring Parameters	System voltage,Current,cell voltage,cell temperature,module temperature



Small-Scale C&I Energy Storage Solution

BOS-A

NEW 161.28kWh HV Battery Set Deye IP20 BOS-A

SKU Code: [11994](#)

21 pcs — 7.68kWh BOS-A-PACK Battery

SKU Code: [12635](#)

1 pcs — Battery Cluster Control Box

SKU Code: [12636](#)

2 pcs — Battery Rack

SKU Code: [12639](#)



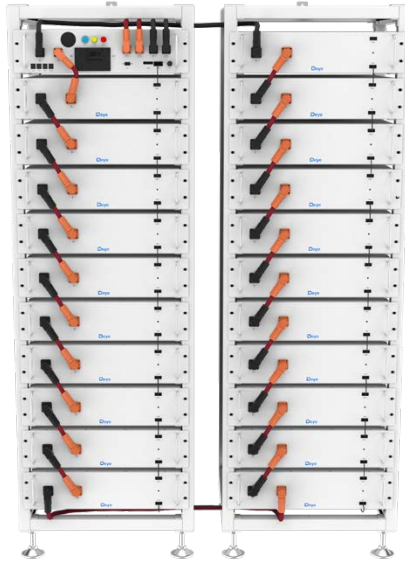

7.68kWh BOS-A-PACK Battery

Cell Chemistry	LiFePO4
Module Energy(kWh)	7.68
Module Nominal Voltage (V)	38.4
Module Capacity (Ah)	200
Module Dimension (W/D/H,mm)	601.5x520x135
Module Weight Approximate (kg)	70
Battery Module Qty in series.	21
System Nominal Voltage (V)	806.4
System Operating Voltage (V)	705.6~919.8
System Energy (kWh)	161.28
System Usable Energy (kWh) 1	145.15
Charge/Discharge Current (A)	Recommend 100 Nominal 160
Working Temperature(°C)	Charge: 0~55/Discharge: -20~55
Status Indicator	Yellow: Battery High Voltage Power On Red: Battery System Alarm
Communication Port	CAN2.0
Humidity	5~85%RH
Altitude	≤3000m
IP Rating of Enclosure	IP20
Dimension (W/D/H,mm)	(610x610x1900) x2
Weight Approximate (kg)	1586
Installation Location	Rack Mounting
Storage Temperature(°C)	0~35
Recommend Depth of Discharge	90%
Cycle Life	25±2°C, 0.5C/0.5C, EOL70%≥6000
Warranty3	10years
Certification	CE/IEC 62619/IEC 62040/VDE-2510/UN 38.3



Small-Scale C&I Energy Storage Solution

BOS-G Pro

NEW

81.92kWh HV Battery Set Deye IP20 BOS-G Pro

 SKU Code: [12355](#)

16 pcs — 5.12kWh BOS-G-Pack 5.1 Battery

 SKU Code: [12346](#)

1 pcs — Battery Cluster Control Box

 SKU Code: [12347](#)

2 pcs — Battery Rack

 SKU Code: [12301](#)



5.12kWh LiFePO4 Battery

Cell Chemistry	LiFePO4						
Module Energy(kWh)	5.12						
Module Nominal Voltage (V)	51.2						
Module Capacity (Ah)	100						
Battery Module Qty in series.	16 (Standard EU Cluster)						
System Nominal Voltage (V)	819.2						
System Operating Voltage (V)	704~934.4						
System Energy (kWh)	81.92						
System Usable Energy (kWh) 1	73.73						
Charge/Discharge Current (A)	<table border="1"> <tr> <td>Recommend</td> <td>50</td> </tr> <tr> <td>Nominal</td> <td>100</td> </tr> <tr> <td>Peak Discharge 2 mins, 25°C</td> <td>125</td> </tr> </table>	Recommend	50	Nominal	100	Peak Discharge 2 mins, 25°C	125
Recommend	50						
Nominal	100						
Peak Discharge 2 mins, 25°C	125						
Working Temperature(°C)	Charge: 0~55/Discharge: -20~55						
Status Indicator	Yellow: Battery High Voltage Power On Red: Battery System Alarm						
Communication Port	CAN2.0/RS485						
Humidity	5~85%RH						
Altitude	≤3000m						
IP Rating of Enclosure	IP20						
Dimension (W/D/H,mm)	1060x602x1629						
Weight Approximate (kg)	837						
Installation Location	Rack Mounting						
Storage Temperature(°C)	0~35						
Recommend Depth of Discharge	90%						
Cycle Life	25±2°C, 0.5C/0.5C, EOL70%≥6000						
Warranty	3years						
Certification	CE/IEC62040/CE-EMC/CEC/VDE/UN38.3						



60kWh HV Battery Set Deye IP20

SKU Code: [11994](#)

12 pcs - 5.12kWh LiFePO4 Battery

SKU Code: [11862](#)

1 pcs — High Voltage Battery Cluster Control Box

SKU Code: [11863](#)

1 pcs - 19inch Rack for Deye Set

SKU Code: [11867](#)

5.12kWh LiFePO4 Battery

Cell Chemistry	LiFePO4						
Module Energy(kWh)	5.12						
Module Nominal Voltage (V)	51.2						
Module Capacity (Ah)	100						
Battery Module Qty in series.	12 (Standard EU Cluster)						
System Nominal Voltage (V)	614.4						
System Operating Voltage (V)	499.2~700						
System Energy (kWh)	61.44						
System Usable Energy (kWh) 1	55.29						
Charge/Discharge Current (A)	<table border="1"> <tbody> <tr> <td>Recommend</td> <td>50</td> </tr> <tr> <td>Nominal</td> <td>100</td> </tr> <tr> <td>Peak Discharge 2 mins, 25°C</td> <td>125</td> </tr> </tbody> </table>	Recommend	50	Nominal	100	Peak Discharge 2 mins, 25°C	125
Recommend	50						
Nominal	100						
Peak Discharge 2 mins, 25°C	125						
Working Temperature(°C)	Charge: 0~55/Discharge: -20~55						
Status Indicator	Yellow: Battery High Voltage Power On Red: Battery System Alarm						
Communication Port	CAN2.0/RS485						
Humidity	5~85%RH						
Altitude	≤2000m						
IP Rating of Enclosure	IP20						
Dimension (W/D/H,mm)	589x590x2240						
Weight Approximate (kg)	628						
Installation Location	Rack Mounting						
Storage Temperature(°C)	0~35						
Recommend Depth of Discharge	90%						
Cycle Life	25±2°C, 0.5C/0.5C, EOL70%≥6000						
Warranty3	10years						
Certification	CE/IEC62619/UL1973/UL9540A/UN38.3						

High Voltage All In One ESS

50kW/60kWh

SKU Code: 11900



10
YEAR
WARRANTY



Rated power operation the maximum temperature of the battery is less than 40°C



BMS integrated technology, power supply redundancy design, support black start function, Off grid operation, etc



Suitable for high rate cyclic charging and discharging scenarios



Combustible gas, smoke and temperature detection, system active exhaust, and fire alarm



Lithium Iron Phosphate (LFP) Battery, The battery pack and system adopt an aerosol fire extinguishing solution



Supports battery expansion, with a maximum capacity of 360KWh

Cell Chemistry	LiFePO4	
Module Energy(kWh)	5.12	
Module Nominal Voltage (V)	51.2	
Module Capacity (Ah)	100	
Battery Module Qty in series.	12 (Standard EU Cluster)	
System Nominal Voltage (V)	614.4	
System Operating Voltage (V)	499.2~700	
System Energy (kWh)	61.44	
System Usable Energy (kWh) 1	55.29	
Rated DC Power	61.44	
Charge/Discharge Current (A)	Recommend	50
	Nominal	100
	Peak Discharge 2 mins, 25°C	125
Working Temperature(°C)	Charge: 0~55/Discharge: -20~55	
Status Indicator	Yellow: Battery High Voltage Power On Red: Battery System Alarm	
Communication Port	CAN2.0/RS485	
Humidity	5~85%RH	
Altitude	≤2000m	
IP Rating of Enclosure	IP65 (After Stacking)	IP20 (Without stacking)
Dimension (W/D/H,mm)	589x590x2240	
Weight Approximate (kg)	628	
Installation Location	Rack Mounting	
Storage Temperature(°C)	0~35	
Recommend Depth of Discharge	90%	
Cycle Life	25±2°C, 0.5C/0.5C, EOL70%≥6000	
Warranty	10years	
Certification	CE/IEC62619/UL1973/UL9540A/UN38.3	

All-in-one Energy Storage System

12kW/15kWh



SYSTEM SPECIFICATION

Nominal Output Power/UPS Power (W)	12000 / 12000
AC Output Frequency and Voltage	50/60Hz; 3L/N/PE 220/380, 230/400Vac
Grid Type	Three Phase
Recommended Energy Configuration	15kWh(Min.)
Max. Charging/Discharging Current (A)	240
Battery Operating Voltage (V)	43.2 ~ 57.6
Battery Chemistry	LiFePO4
IP Rating of Enclosure	IP65 (After stacking) IP20 (Without stacking)
System Certification	IEC62619, IEC60730, CE, VDE2510-50, CEI 0-21
Warranty [1]	Battery 10 years (Inverter 10 years)

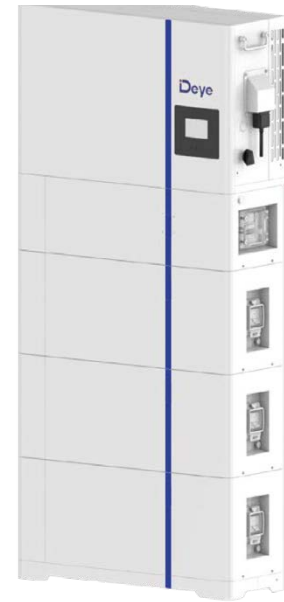

INVERTER TECHNICAL SPECIFICATION

Max. PV Input Power (W)	15600
Rated PV Input Voltage (Vdc)	550 (160~800)
Start Up DC Voltage (Vdc)	160
MPPT Voltage Range (Vdc)	200~650
Full Load DC Voltage Range (V)	350~650
Max. PV Input Current (A)	26+13
Max. PV Short-circuit Current (A)	34+17
No. of MPP Trackers	2
Peak Power (off grid)	2 time of rated power, 10s
Power Factor	0.8 leading to 0.8 lagging
DC injection current (mA)	THD<3% (Linear load<1.5%)
Display	LCD
Relative Humidity	15% ~ 85% (No Condensing)
Dimension (W x D x H,mm)	720x255x440
Weight (kg)	38
Communication with BMS	CAN2.0
Max. Efficiency	97.60%
Max. charging/discharging efficiency	95.50%

5.12kWh Solar Battery

SKU Code: [12186](#)

12kW Hybrid Solar Inverter-Three Phase

SKU Code: [12190](#)

Power Distribute Unit III+ Base

SKU Code: [12187](#)

BMS

SKU Code: [12188](#)

BATTERY TECHNICAL SPECIFICATION

Nominal Voltage (V)	51.2
Battery Module Energy (kWh)	5.12
Module Scalability	Max.36 pcs in parallel(Max. capacity of 184kWh)
Battery Module Dimension	720*255*300(W x D x H, mm)
Battery Base Dimension	720*255*68(W x D x H, mm)
Battery PDU3 Dimension	720*255*228(W x D x H, mm)
Battery Module Weight (kg)	53
Operating Temperature Range	Charge: 0~55°C / Discharge: -20°C~+55°C
Cycle Life	≥6000(25°C±2°C,0.5C/0.5C, 90%DOD,70%EOL)

EMC/Safety Regulation

IEC/EN 62109-1,IEC/EN 62109-2,IEC/EN 61000-6-1,IEC/EN 61000-6-2,IEC/EN 61000-6-3,IEC/EN 61000-6-4

Grid Regulation

VDE4105,IEC61727/62116,VDE0126, AS4777.2,CEI 0-21,EN50549-1,G98, G99,C10-11,UNE217002, NBR16149/NBR16150

Battery Module

IEC62619, CE, UK, VDE2510-50, CEI 0-21, UN38.3, CE-LVD, CEC

GENERAL PURPOSE BATTERIES

LiFePO4 & Lead Acid

V-TAC
Meaningful Innovation.



The general-purpose batteries have low energy density but as they supply high power current surges makes them used for the respective purposes. They have a high Energy density to weights ratio.

- Outdoor and indoor UPS and battery back-up systems.
- Portable and cordless household appliances.
- Medical equipment, motorcycles, toy cars, camping trailers, RVs, etc.
- Lighting equipment, emergency lights, etc.



Lithium Iron Phosphate Battery



Model No: **VT-12.8V 10AH-L**
SKU Code: **11940**

Model No: **VT-12.8V 2.3AH-L**
SKU Code: **11941**

ELECTRICAL DATA

Nominal Voltage
Nominal Capacity
Energy
Resistance
Self Discharge
Cells Square Cell

12.8 V
10 Ah
128 Wh
≤30 mΩ @ 50% SOC
<3% / Month
Cells Square Cell 3.2V10Ah

12.8 V
2.3 Ah
29.44 Wh
≤30 mΩ @ 50% SOC
<3% / Month
Square Cell 3.2V2.3Ah

MECHANICAL DATA

Dimension (L x W x H)
Approx. Weight
Terminal Type
Terminal Torque
Case Material
Enclosure Protection

L151*W98*H97mm
1.43KG
T2
/
ABS
IP55

L178*W35*H60mm
380g±5g
T2
/
ABS
IP55

DISCHARGE PERFORMANCE

Continuous Discharge Current
Maximum continuous Discharge Current
Peak Discharge Cut-Off Current
Recommended Low Voltage Disconnect
Discharge Cut-Off Voltage
Reconnect Voltage
Short Circuit Protection

5 A
10 A
50±10A
10 V
10 V
11.2 V
500±300(microsecond)

1.15 A
2.3 A
50±10A
10 V
10 V
11.2 V
500±300(microsecond)

CHARGE PERFORMANCE

Recommended Charge Current
Maximum Charge Current
Recommended Charge Voltage
Charge Cut-Off Voltage
Reconnect Voltage
Balancing Voltage
Maximum Batteries in Series
Maximum Batteries in Parallel

2 A
5 A
14.6 V
<15.2 V (0.5 ~ 1.5 s)
>14.4 V
<14 V
1
1

0.46 A
1.15 A
14.6 V
<15.2 V (0.5 ~ 1.5 s)
>14.4 V
<14 V
1
1

TEMPERATURE PERFORMANCE

Discharge Temperature
Charge Temperature
Storage Temperature
High Temperature Cut-Off
Reconnect Temperature

-4 ~ 140 °F (-20 ~ 60 °C)
32 ~ 113 °F (0 ~ 45 °C)
23 ~ 95 °F (-5 ~ 35 °C)
149 °F (65 °C)
118 °F (48 °C)

Lithium Iron Phosphate Battery



ELECTRICAL DATA

Nominal Voltage
Nominal Capacity
Energy
Resistance
Self Discharge
Cells Square Cell

Model No:	VT-12.8V 7.2AH-L
SKU Code:	11942
12.8 V	
7.2 Ah	
92.16 Wh	
≤30 mΩ @ 50% SOC	
<3% / Month	
Square Cell 3.2V7.2Ah	

Model No:	VT-6.4V 5AH-L
SKU Code:	11943
6.4 V	
5 Ah	
32 Wh	
≤30 mΩ @ 50% SOC	
<3% / Month	
Square Cell 3.2V5Ah	

MECHANICAL DATA

Dimension (L x W x H)
Approx. Weight
Terminal Type
Terminal Torque
Case Material
Enclosure Protection

L150*W63*H93mm
850g±3g
T2
/
ABS
IP55

L70*W47*H99mm
380g±5g
T2
/
ABS
IP55

DISCHARGE PERFORMANCE

Continuous Discharge Current
Maximum continuous Discharge Current
Peak Discharge Cut-Off Current
Recommended Low Voltage Disconnect
Discharge Cut-Off Voltage
Reconnect Voltage
Short Circuit Protection

3.6 A
7.2 A
50±10A
10 V
10 V
11.2 V
500±300(microsecond)

2.5 A
5 A
50±10A
5 V
5 V
5.6 V
500±300(microsecond)

CHARGE PERFORMANCE

Recommended Charge Current
Maximum Charge Current
Recommended Charge Voltage
Charge Cut-Off Voltage
Reconnect Voltage
Balancing Voltage
Maximum Batteries in Series
Maximum Batteries in Parallel

1.44 A
3.6A
14.6 V
<15.2 V (0.5 ~ 1.5 s)
>14.4 V
<14 V
1
1

1 A
2.5 A
7.3 V
<7.6 V (0.5 ~ 1.5 s)
>7.2 V
<7 V
1
1

TEMPERATURE PERFORMANCE

Discharge Temperature
Charge Temperature
Storage Temperature
High Temperature Cut-Off
Reconnect Temperature

-4 ~ 140 °F (-20 ~ 60 °C)
32 ~ 113 °F (0 ~ 45 °C)
23 ~ 95 °F (-5 ~ 35 °C)
149 °F (65 °C)
118 °F (48 °C)

NEW Lead Acid Batteries



6V/4Ah (20hr)

SKU Code: 23448

Nominal Voltage	6V
Nominal Capacity	4 Ah
Terminal	T1
Approx. Weight	Approx 0.67 kg (1.47 lbs)
Container Material	ABS
Rated Capacity	20Hour Rate (0.2A to 10.8V) 4.00Ah
	10Hour Rate (0.367A to 10.8V) 3.67Ah
	3Hour Rate (1.1A to 10.5V) 3.30Ah
Internal resistance	Full charged at 25°C: 25 Ohm
Max. Discharge Current	67.5A(5S)
Operating Temperature	Discharge: -15 -50°C(5- 122°F)
	Charge: 0-40°C (32-104°F) Storage: -15-40°C(5-104°F)
Charge Voltage(25°C)	Max. charge Current: 1.2A
	Cycle use: 7.2-7.5V(-30mV/ °C)
	Float use : 6.75-6.9V(-20mV/ °C)
Self discharge	3% of capacity declined per month at 20°C
Dimension(mm)	70(L)x47(W)x101(H)x106(TH)



12V/7Ah (20hr)

SKU Code: 23451

Nominal Voltage	12V
Nominal Capacity	4 Ah
Terminal	T1
Approx. Weight	Approx 2.4kg (4.49lbs)
Container Material	ABS
Rated Capacity	20Hour Rate (0.350A to 10.8V) 7.00Ah
	10Hour Rate (0.653A to 10.8V) 6.53Ah
	3Hour Rate (1.710A to 10.5V) 5.13Ah
Internal resistance	Full charged at 25°C: 28 Ohm
Max. Discharge Current	105A(5S)
Operating Temperature	Discharge: -15 -50°C(5- 122°F)
	Charge: 0-40°C (32-104°F) Storage: -15-40°C(5-104°F)
Charge Voltage(25°C)	Max. charge Current: 2.1A
	Cycle use: 14.4-15.0V(-30mV/ °C)
	Float use : 13.5-13.8V(-20mV/ °C)
Self discharge	3% of capacity declined per month at 20°C
Dimension(mm)	151(L)x65(W)x94(H)x100(TH)

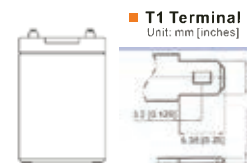
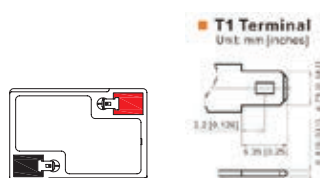
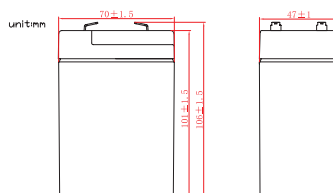

NEW Lead Acid Batteries



12V/1.3Ah (20hr)

SKU Code: 23449

Nominal Voltage	12V
Nominal Capacity	1.3Ah
Terminal	T1
Approx. Weight	Approx 0.54 kg (1.19 lbs)
Container Material	ABS
Rated Capacity	20Hour Rate (0.065A to 10.8V) 1.3Ah
	10Hour Rate (0.1A to 10.8V) 1.0Ah
	3Hour Rate (0.166A to 10.5V) 0.5Ah
Internal resistance	Full charged at 25°C: 16 Ohm
Max. Discharge Current	18A(5S) Discharge: -15 -50°C(5- 122°F)
Operating Temperature	Charge: 0-40°C (32-104°F)
	Storage: -15-40°C(5-104°F)
Charge Voltage(25°C)	Max. charge Current: 0.39A
	Cycle use: 14.4-15.0V(-30mV/ °C)
	Float use : 13.5-13.8V(-20mV/ °C)
Self discharge	3% of capacity declined per month at 20°C
Dimension(mm)	97(L)x43(W)x51.5(H)x57.5(TH)

12V/2Ah (20hr)

SKU Code: 23450

Nominal Voltage	12V
Nominal Capacity	2Ah
Terminal	T1
Approx. Weight	Approx 0.81kg (1.78lbs)
Container Material	ABS
Rated Capacity	20Hour Rate (0.1A to 10.8V) 2Ah
	10Hour Rate (0.15A to 10.8V) 1.5Ah
	3Hour Rate (0.26A to 10.5V) 0.8Ah
Internal resistance	Full charged at 25°C: 16 Ohm
Max. Discharge Current	28.5A(5S) Discharge: -15 -50°C(5- 122°F)
Operating Temperature	Charge: 0-40°C (32-104°F)
	Storage: -15-40°C(5-104°F)
Charge Voltage(25°C)	Max. charge Current: 0.6A
	Cycle use: 14.4-15.00V(-30mV/ °C)
	Float use : 13.5-13.8V(-20mV/ °C)
Self discharge	3% of capacity declined per month at 20°C
Dimension(mm)	178(L)x36(W)x61(H)x66(TH)

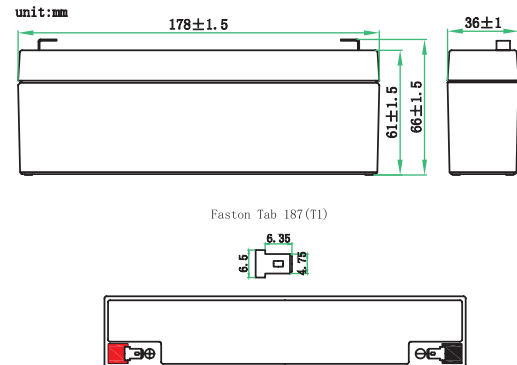
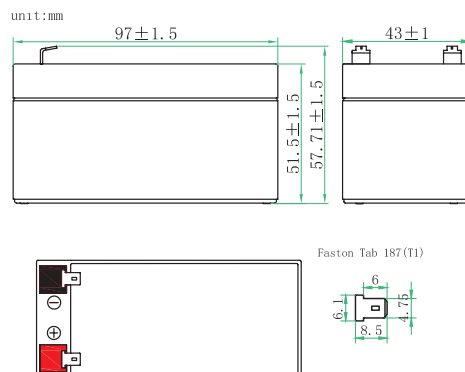

Lead Acid Batteries



12V/10Ah (20hr)

SKU Code: 23452

Nominal Voltage	12V
Nominal Capacity	10Ah
Terminal	T2
Approx. Weight	Approx 3.10 kg (6.83lbs)
Container Material	ABS
Rated Capacity	20Hour Rate (.50A to 10.8V) 10Ah
	10Hour Rate (0.93A to 10.8V) 9.3Ah
	3Hour Rate (2.55A to 10.5V) 7.65Ah
Internal resistance	Full charged at 25°C: 16 Ohm
Max. Discharge Current	150A(5S)
Operating Temperature	Discharge: -15 -50°C(5- 122°F)
	Charge: 0-40°C (32-104°F) Storage: -15-40°C(5-104°F)
Charge Voltage(25°C)	Max. charge Current: 3A
	Cycle use: 14.4-15.0V(-30mV/ °C)
	Float use : 13.5-13.8V(-20mV/ °C)
Self discharge	3% of capacity declined per month at 20°C
Dimension(mm)	151(L)x98(W)x95(H)x101(TH)



12V/18Ah (20hr)

SKU Code: 23453

Nominal Voltage	12V
Nominal Capacity	18Ah
Terminal	M5
Approx. Weight	Approx 5.10kg (11.35lbs)
Container Material	ABS
Rated Capacity	20Hour Rate (0.90A to 10.8V) 18Ah
	10Hour Rate (1.67A to 10.8V) 16.7Ah
	3Hour Rate (4.46A to 10.5V) 13.4Ah
Internal resistance	Full charged at 25°C: 16 Ohm
Max. Discharge Current	270A(5S)
Operating Temperature	Discharge: -15 -50°C(5- 122°F)
	Charge: 0-40°C (32-104°F) Storage: -15-40°C(5-104°F)
Charge Voltage(25°C)	Max. charge Current: 5.4A
	Cycle use: 14.4-15.0V(-30mV/ °C)
	Float use : 13.5-13.8V(-20mV/ °C)
Self discharge	3% of capacity declined per month at 20°C
Dimension(mm)	180(L)x77(W)x167(H)x167(TH)

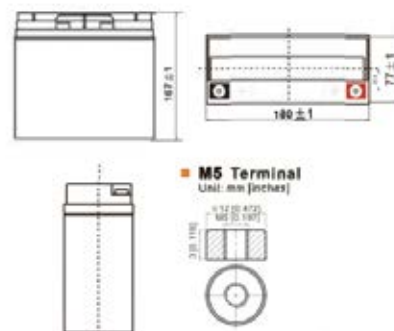
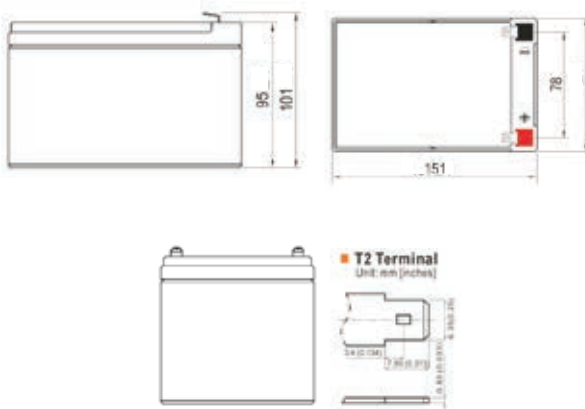

Lead Acid Batteries



12V/26Ah (20hr)

SKU Code: 23454

Nominal Voltage	12V
Nominal Capacity	26Ah
Terminal	M5
Approx. Weight	Approx 7.8 kg (17.19 lbs)
Container Material	ABS
Rated Capacity	20Hour Rate (1.30A to 10.8V) 26Ah
	10Hour Rate (2.42A to 10.8V) 24.2Ah
	3Hour Rate (6.63A to 10.5V) 19.9Ah
Internal resistance	Full charged at 25°C:14 Ohm
Max. Discharge Current	390(5S) Discharge: -15 -50°C(5- 122°F)
Operating Temperature	Charge: 0-40°C (32-104°F)
	Storage: -15-40°C(5-104°F)
Charge Voltage(25°C)	Max. charge Current: 7.8A
	Cycle use: 14.4-15V(-30mV/ °C)
	Float use : 13.5-13.8V(-20mV/ °C)
Self discharge	3% of capacity declined per month at 20°C
Dimension(mm)	166(L)x175(W)x125(H)x125(TH)



12V/7Ah (20hr)

SKU Code: 23467

Nominal Voltage	12V
Nominal Capacity	4 Ah
Terminal	T2
Approx. Weight	Approx 2.4kg (4.49lbs)
Container Material	ABS
Rated Capacity	20Hour Rate (0.350A to 10.8V) 7.00Ah
	10Hour Rate (0.653A to 10.8V) 6.53Ah
	3Hour Rate (1.710A to 10.5V) 5.13Ah
Internal resistance	Full charged at 25°C: 28 Ohm
Max. Discharge Current	105A(5S) Discharge: -15 -50°C(5- 122°F)
Operating Temperature	Charge: 0-40°C (32-104°F)
	Storage: -15-40°C(5-104°F)
Charge Voltage(25°C)	Max. charge Current: 2.1A
	Cycle use: 14.4-15.0V(-30mV/ °C)
	Float use : 13.5-13.8V(-20mV/ °C)
Self discharge	3% of capacity declined per month at 20°C
Dimension(mm)	151(L)x65(W)x94(H)x100(TH)

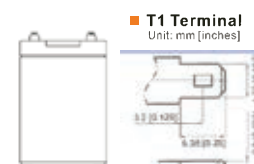
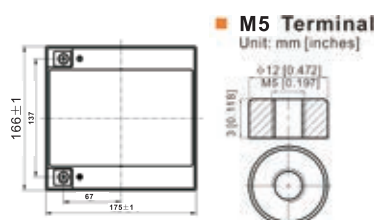
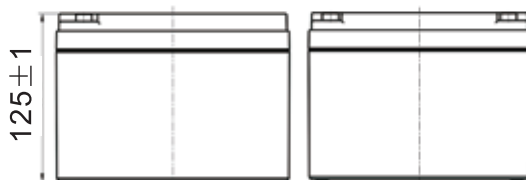

SOLAR PANELS

V-TAC
Meaningful Innovation.



HALF-CUT TECHNOLOGY

Unique circuit design to reduce temperature heat spots



SIGNIFICANTLY AVOIDING HEAT SPOT

The unique circuit design helps reduce the temperature heat spot of cells significantly to reduce the power loss and increase energy output of modules



LOWER COST

Increasing power generation can reduce the cost per kilowatt-hour



**Anti
PID**

EXCELLENT PERFORMANCE OF PID RESISTANCE

The performance of PID resistance (Potential Induced Degradation) passes all TUV NORD current testing criteria

UP TO

15 YEAR
WARRANTY
PRODUCT MATERIAL

UP TO

30 YEAR
WARRANTY
LINEAR POWER OUTPUT

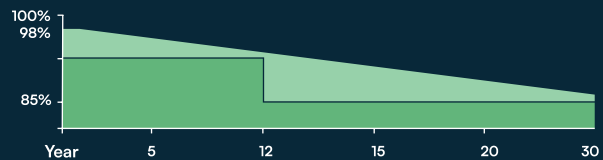

- Maximum Cell Efficiency
- Maximum Positive Power Tolerance gives highest output per m2 of roof
- Aesthetically pleasing All Black Panel / Frame available
- Highest Heat Tolerance

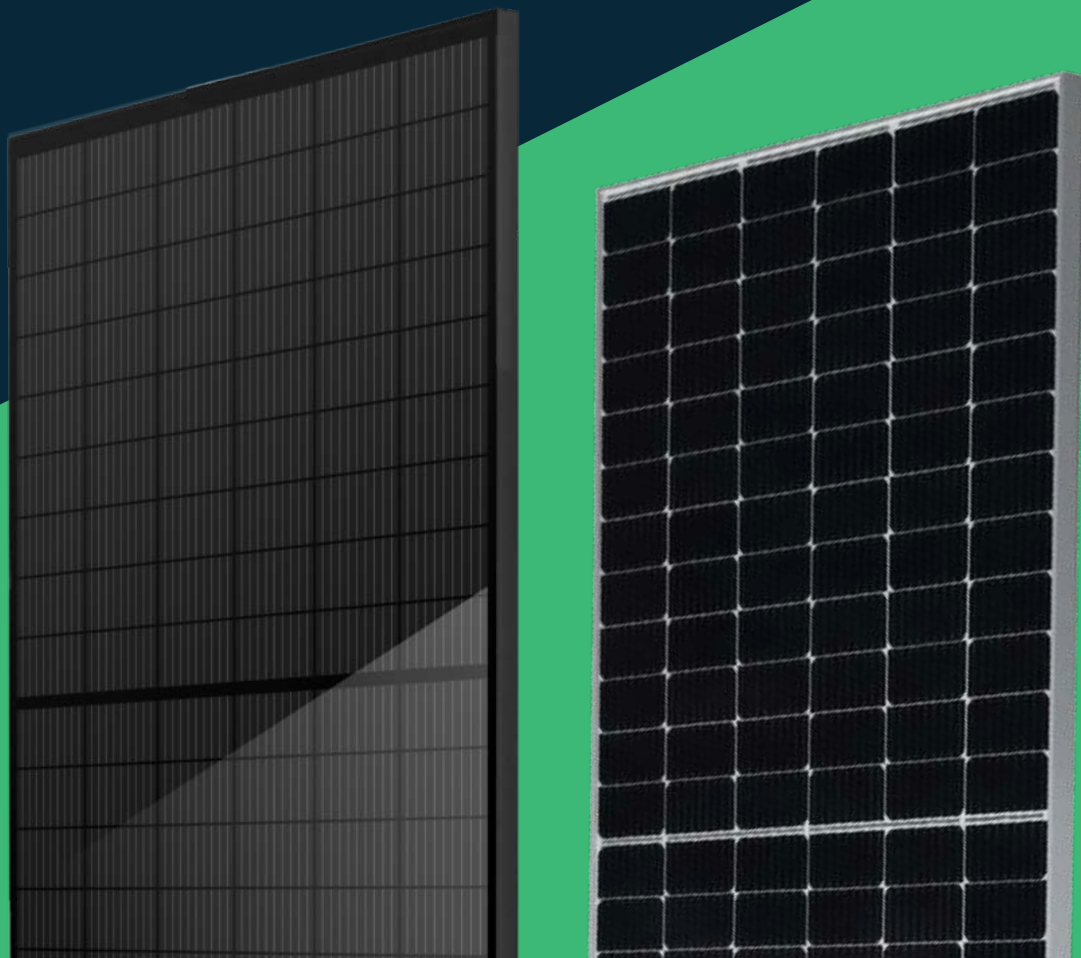

440W NEW

Double Glass Bifacial TOPCon Technology Solar Panel



Model No:	ODA440-27V-MHDB
SKU Code:	12269
EAN Code:	3800170227194
20FT container:	6 pallets/222pcs
40FT container	26 pallets/962pcs

ELECTRICAL DATA (STC)

Peak Power(Pmax)	440.00
Maximum Power Voltage(Vmp)	32.24
Maximum Power Current(Imp)	13.65
Open Circuit Voltage(Voc)	38.87±3%
Short Circuit Current(Isc)	14.39±3%
Module Efficiency(%)	22.54

ELECTRICAL DATA (NOCT)

Peak Power(Pmax)	331.00
Maximum Power Voltage(Vmp)	29.91
Maximum Power Current(Imp)	11.07
Open Circuit Voltage(Voc)	36.92±3%
Short Circuit Current(Isc)	11.63±3%

ELECTRICAL DATA(BNPI)

Peak Power(Pmax)	488.00
Maximum Power Voltage(Vmp)	32.24
Maximum Power Current(Imp)	15.14
Open Circuit Voltage(Voc)	38.87±3%
Short Circuit Current(Isc)	15.94±3%

MECHANICAL CHARACTERISTICS

Cell Type	182 *91 N Type Bifacial Mono
No. of cells	108(12 *9)
Dimensions	1722 * 1134 *30mm
weight	24.70kg
Front Glass	2.0mm AR coating tempered glass
Back Glass	2.0mm Glazed Glass
Frame	Anodized Aluminium Alloy
Junction box	IP68 3diodes
Output cables	4mm2 cable 35cm (Including Mc4 connector)
Maxwind Load/snow Load	2400pa/5400pa
Class of Safety Protection	Class II
IEC Component Fire Rating	Class C

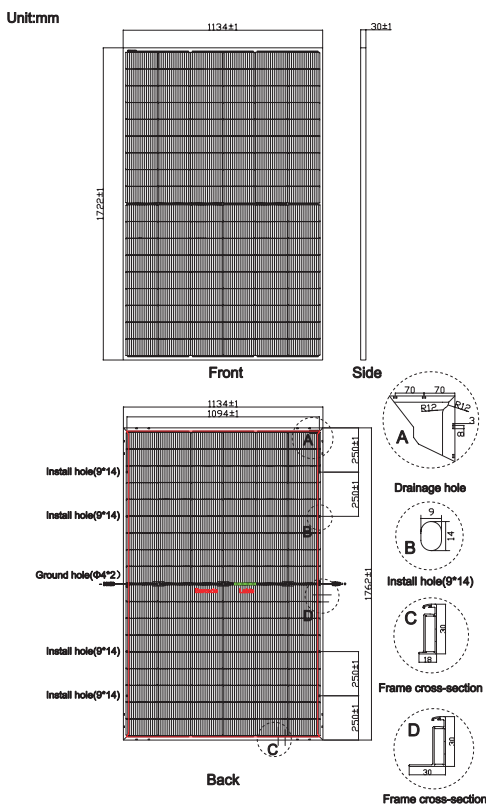

TEMPERATURE & MAXIMUM RATING

Maximum System Voltage (V)	1500
Maximum Series Fuse Rating (A)	30
Power Tolerance	0~+3
Pmax Temperature Coefficient (W/°C)	-0.290 %
Voc Temperature Coefficient (V/°C)	-0.250 %
Isc Temperature Coefficient (A/°C)	+0.041 %
NOCT Nominal Operating Cell Temperature (°C)	45±2
Operating and Storage Temperature (°C)	-40~+85

440W

NEW

N-Type Monofacial Solar Panel



Model No:	ODA440-27V-MH
SKU Code:	12350
EAN Code:	3800170241404
Number Of Modules Per Pallet	37
Number Of Pallets Per Container	26
Number Of Modules Per Container	962

SPECIFICATION (STC)

Rated Peak Power-Pmax(Wp)	440.00
Maximum Power Voltage-Vmp(V)	33.72
Maximum Power Current-Imp(A)	13.04
Open Circuit Voltage-Voc(V)	39.67±3%
Short Circuit Current-Isc(A)	13.86±3%
Module Efficiency(%)	22.53

Irradiance at 1000 W/m², Cell Temp 25°C, Air Mass AM1.5

TEMP COEFFICIENT

Temp Coefficient Of Pmax	-0.290%/°C
Temp Coefficient Of Voc	-0.250%/°C
Temp Coefficient Of Isc	+0.045%/°C

OPERATING PARAMETERS

Maximum System Voltage	1500V
Operational Temp	-40~+85 °C
Max Series Fuse Rating	20A
Nominal Module Operating Temp (NMOT)	45±2°C

Unit:mm

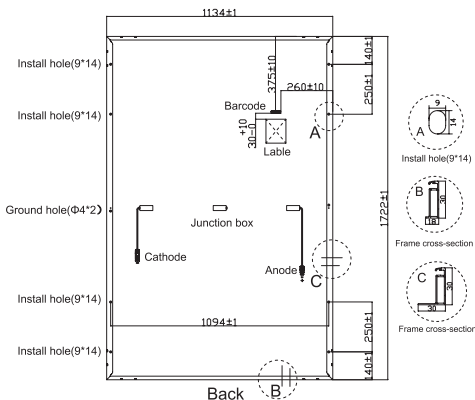
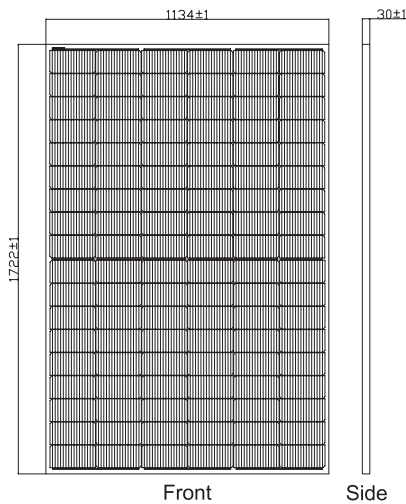

MECHANICAL CHARACTERISTICS

Cell Type (mm)	182*91 N-Type Mono
No. Of Cells	108(12*9)
Module Dimensions(mm)	1722*1134*30
Weight	21.50kg
Monofacial Glass Front Glass(mm)	3.2mm AR Coating Tempered Glass
Frame	Anodized Aluminium Alloy(Silver)
Junction Box	IP68,1500VDC, 3 Schottky Bypass Diodes
Connector	IP68
Snow Load/Wind Load	5400Pa/2400Pa
Class Of Safety Protection	Class II
IEC Component Fire Rating	Class C
Cables	4.0mm ² ,Positive(+)300mm,Negative(-)300mm ,Or Customized Length

440W

NEW

N-Type Monofacial Solar Panel Full-Black



Model No:	ODA440-27V-MHB
SKU Code:	12351
EAN Code:	3800170241411
Number Of Modules Per Pallet	37
Number Of Pallets Per Container	26
Number Of Modules Per Container	962

SPECIFICATION (STC)

Rated Peak Power-Pmax(Wp)	440.00
Maximum Power Voltage-Vmp(V)	33.72
Maximum Power Current-Imp(A)	13.04
Open Circuit Voltage-Voc(V)	39.67±3%
Short Circuit Current-Isc(A)	13.86±3%
Module Efficiency(%)	22.53

Irradiance at 1000 W/m², Cell Temp 25°C, Air Mass AM1.5

TEMP COEFFICIENT

Temp Coefficient Of Pmax	-0.290%/°C
Temp Coefficient Of Voc	-0.250%/°C
Temp Coefficient Of Isc	+0.045%/°C

OPERATING PARAMETERS

Maximum System Voltage	1500V
Operational Temp	-40~+85 °C
Max Series Fuse Rating	20A
Nominal Module Operating Temp (NMOT)	45±2°C

Unit:mm

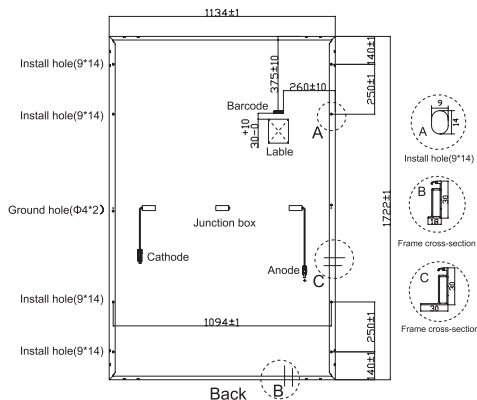
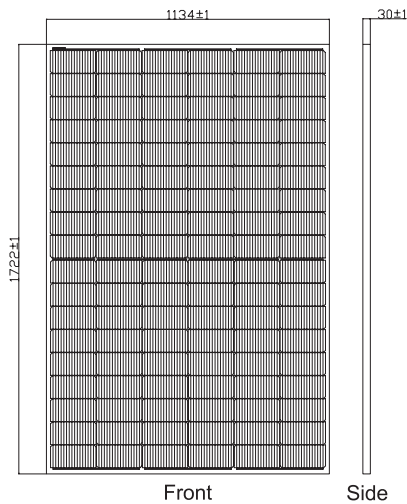

MECHANICAL CHARACTERISTICS

Cell Type (mm)	182*91 N-Type Mono
No. Of Cells	108(12*9)
Module Dimensions(mm)	1722*1134*30
Weight	21.50kg
Monofacial Glass Front Glass(mm)	3.2mm AR Coating Tempered Glass
Frame	Anodized Aluminium Alloy(Silver)
Junction Box	IP68,1500VDC, 3 Schottky Bypass Diodes
Connector	IP68
Snow Load/Wind Load	5400Pa/2400Pa
Class Of Safety Protection	Class II
IEC Component Fire Rating	Class C
Cables	4.0mm ² , Positive(+)300mm, Negative(-)300mm, Or Customized Length

450W **NEW**

Double Glass N-Type Solar Panel

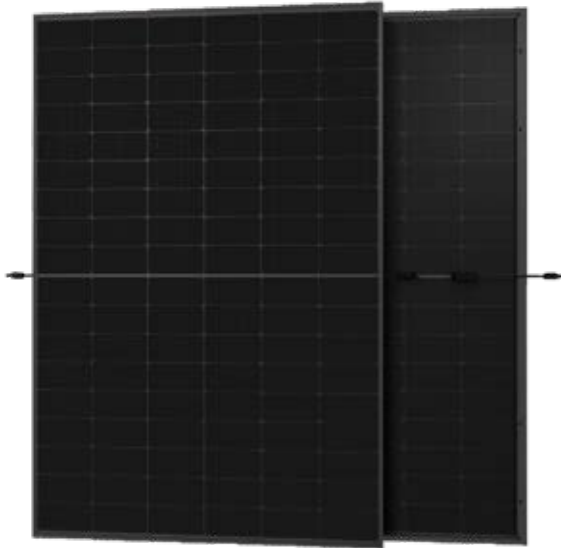

Model No:	ODA450-27V-MHDB
SKU Code:	12273
EAN Code:	3800170227262
20FT container:	6 pallets/222pcs
40FT container:	26 pallets/962pcs

ELECTRICAL DATA (STC)

Peak Power(Pmax)	450.00
Maximum Power Voltage(Vmp)	32.82
Maximum Power Current(Imp)	13.71
Open Circuit Voltage(Voc)	39.30±3%
Short Circuit Current(Isc)	14.48±3%
Module Efficiency(%)	22.5

ELECTRICAL DATA (NOCT)

Peak Power(Pmax)	341.00
Maximum Power Voltage(Vmp)	31.06
Maximum Power Current(Imp)	10.97
Open Circuit Voltage(Voc)	37.19±3%
Short Circuit Current(Isc)	11.58±3%

ELECTRICAL DATA(BNPI)

Peak Power(Pmax)	499.00
Maximum Power Voltage(Vmp)	32.82
Maximum Power Current(Imp)	15.20
Open Circuit Voltage(Voc)	39.30±3%
Short Circuit Current(Isc)	16.03±3%

Unit:mm

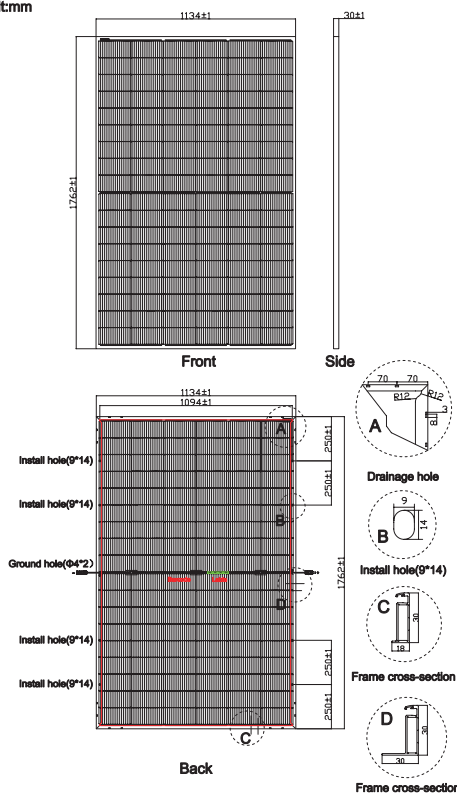

MECHANICAL CHARACTERISTICS

Cell Type	182 *94 Mono
No. of cells	108(12 *9)
Dimensions	1762 * 1134 *30mm
Weight	25kg
Front Glass	2.0mm AR coating tempered glass
Back Glass	2.0mm Glazed Glass
Frame	Anodized Aluminium Alloy
Junction box	IP68 3diodes
Output cables	4mm2 cable 35cm (Including Mc4 connector)
Maxwind Load/snow Load	2400pa/5400pa

TEMPERATURE & MAXIMUM RATING

Maximum System Voltage (V)	1500
Maximum Series Fuse Rating (A)	30
Power Tolerance	0~+3
Pmax Temperature Coefficient (W/°C)	-0.290 %
Voc Temperature Coefficient (V/°C)	-0.250 %
Isc Temperature Coefficient (A/°C)	+0.041 %
NOCT Nominal Operating Cell Temperature (°C)	45±2
Operating and Storage Temperature (°C)	-40~+85

455W NEW
DUAL GLASS Trinasolar
N-Type i-TOPCon MODULE

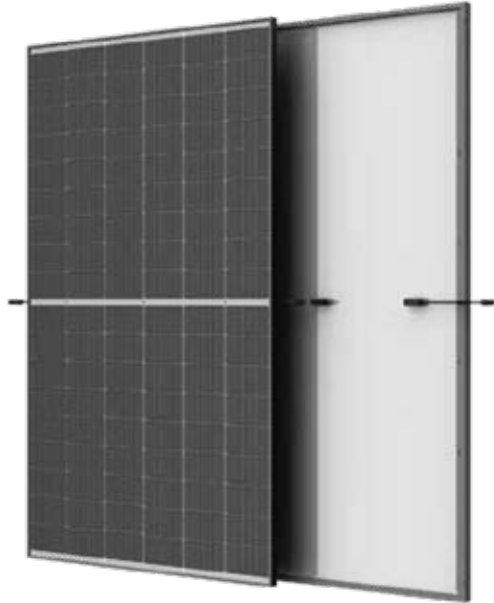

Model No:	TSM-455-NEG9R.28
SKU Code:	12642
EAN Code:	3800170251946
Modules per box:	36 pieces
Modules per 40' container:	936 pieces

ELECTRICAL DATA (STC)

Peak Power Watts-PMAX (Wp)*	455
Power Selection (W)**	0/+5
Maximum Power Voltage-VMPP (V)	45.0
Maximum Power Current-IMPP (A)	10.11
Open Circuit Voltage-VOC (V)	53.4
Short Circuit Current-ISC (A)	10.77
Module Efficiency η (%)	22.8

ELECTRICAL DATA(NOCT)

Maximum Power-PMAX (Wp)	348
Maximum Power Voltage-VMPP (V)	42.3
Maximum Power Current-IMPP (A)	8.22
Open Circuit Voltage-VOC (V)	50.6
Short Circuit Current-ISC (A)	8.68

DIMENSIONS OF PV MODULE (mm)

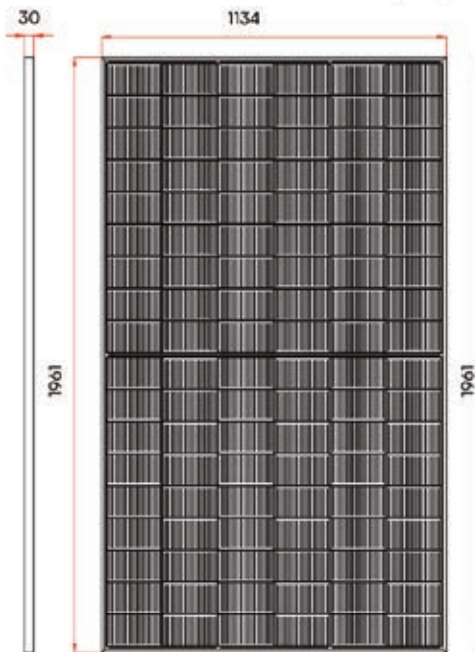

Front View

MECHANICAL CHARACTERISTICS

Solar Cells	Monocrystalline
No. of cells	144 cells
Module Dimensions	1762×1134×30 mm
Weight	21 kg
Front Glass	1.6 mm, High Transmission, AR Coated Heat Strengthened Glass
Back Glass	1.6 mm, Heat Strengthened Glass
Frame	30 mm Anodized Aluminium Alloy, Black
J-Box	IP 68 rated
Connector	TS4 / TS4 Plus / MC4 EVO2*
Cables	Photovoltaic Technology Cable 4.0 mm ²
	Landscape: 1300/1300 mm
	Portrait: 280/350 mm*

TEMPERATURE & MAXIMUM RATING

NOCT(Nominal Operating Cell Temperature)	43°C (±2°C)
Temperature Coefficient of PMAX	-0.29%/°C
Temperature Coefficient of VOC	-0.24%/°C
Temperature Coefficient of ISC	0.04%/°C
Operational Temperature	-40 to +85 °C
Maximum System Voltage	1500 V DC (IEC)
Max Series Fuse Rating	25A

455W **NEW**

N-Type Monofacial Solar Panel



Model No:	JKM455N-54HL4R-V
SKU Code:	12645
EAN Code:	3800170252073
Pallet Dimensions	1792×1140×1249 mm
Packing detail (Two pallets=One stack)	37 pcs/pallets, 74 pcs/stack, 962 pcs/ 40'HQ Container

ELECTRICAL DATA (STC)

Maximum Power - Pmax [Wp]	455
Maximum Power Voltage - Vmp [V]	33.41
Maximum Power Current - Imp [A]	13.62
Open-circuit Voltage - Voc [V]	39.98
Short-circuit Current - Isc [A]	14.07
Module Efficiency STC [%]	22.77
Power Tolerance	0 ~ + 3 %
Temperature Coefficients of Pmax	-0.29 %/°C
Temperature Coefficients of Voc	-0.25 %/°C
Temperature Coefficients of Isc	0.045 %/°C

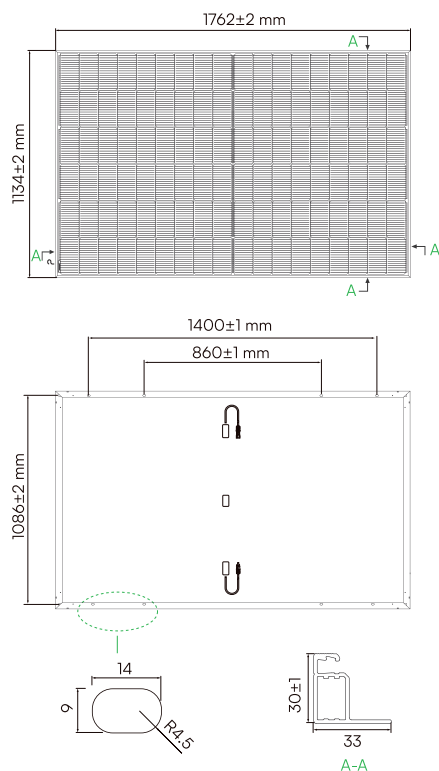

MECHANICAL CHARACTERISTICS

Cell Type	N -type Mono-crystalline
No. of cells	108 (54×2)
Dimensions	1762×1134×30 mm
Weight	21.0 kg
Frame	Anodized Aluminium Alloy
Junction Box	IP68 Rated
Protection Class	Class II
IEC Fire Type	Class C
Connector Type	JK03M/MC4/Others
Output Cables	4.0 mm ² -(+): 400 mm , (-): 200 mm or Customized Length
Front Glass	3.2mm, Anti-reflection Coating, High Transmission, Low Iron, Tempered Glass

APPLICATION CONDITIONS

Operating Temperature	-40 °C ~ +70°C
Maximum System Voltage	1000/1500 VDC (IEC)
Maximum Series Fuse Rating	25 A

460W **NEW**

Double Glass Bifacial TOPCon Technology Solar Panel



Model No:	ODA460-27VR-MHDB
SKU Code:	12270
EAN Code:	3800170227200
20FT container:	6 pallets/222pcs
40FT container:	26 pallets/962pcs

ELECTRICAL DATA (STC)

Peak Power(Pmax)	460.00
Maximum Power Voltage(Vmp)	33.18
Maximum Power Current(Imp)	13.86
Open Circuit Voltage(Voc)	39.70±3%
Short Circuit Current(Isc)	14.64±3%
Module Efficiency(%)	23.0

ELECTRICAL DATA (NOCT)

Peak Power(Pmax)	348.00
Maximum Power Voltage(Vmp)	31.39
Maximum Power Current(Imp)	11.10
Open Circuit Voltage(Voc)	37.56±3%
Short Circuit Current(Isc)	11.71±3%

ELECTRICAL DATA(BNPI)

Peak Power(Pmax)	510.00
Maximum Power Voltage(Vmp)	33.18
Maximum Power Current(Imp)	15.37
Open Circuit Voltage(Voc)	39.70±3%
Short Circuit Current(Isc)	16.20±3%

MECHANICAL CHARACTERISTICS

Cell Type	182*94 N Type Bifacial Mono
No. of cells	108(12*9)
Dimensions	1762*1134*30mm
weight	25.00kg
Front Glass	2.0mmAR coating tempered glass
Back Glass	2.0mm Glazed Glass
Frame	Anodized Aluminium Alloy
Junction box	IP68 3diodes
Output cables	4mm2 cable 35cm(Including Mc4 connector)
Maxwind Load/snow Load	2400pa/5400pa
Class of Safety Protection	Class II
IEC Component Fire Rating	Class C

Unit:mm

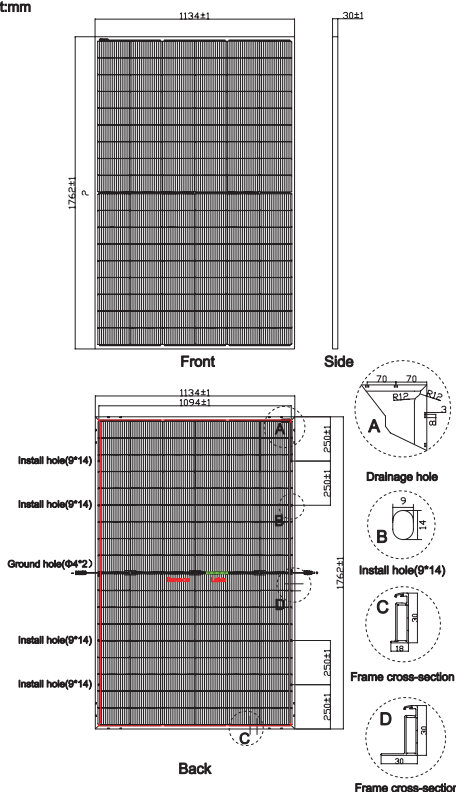

TEMPERATURE & MAXIMUM RATING

Maximum System Voltage (V)	1500
Maximum Series Fuse Rating (A)	30
Power Tolerance	0~+3
Pmax Temperature Coefficient (W/°C)	-0.290 %
Voc Temperature Coefficient (V/°C)	-0.250 %
Isc Temperature Coefficient (A/°C)	+0.041 %
NOCT Nominal Operating Cell Temperature (°C)	45±2
Operating and Storage Temperature (°C)	-40~+85

480W **NEW**

N-Type Monofacial Solar Panel

SKU Code: 12285



ELECTRICAL DATA (STC)

Rated Peak Power-Pmax(Wp)	480.00
Maximum Power Voltage-Vmp(V)	35.37
Maximum Power Current-Imp(A)	13.57
Open Circuit Voltage-Voc(V)	42.70±3%
Short Circuit Current-Isc(A)	14.31±3%
Module Efficiency(%)	22.24

ELECTRICAL DATA (NOCT)

Rated Peak Power-Pmax(Wp)	361.00
Maximum Power Voltage-Vmp(V)	33.26
Maximum Power Current-Imp(A)	10.85
Open Circuit Voltage-Voc(V)	40.57±3%
Short Circuit Current-Isc(A)	11.56±3%

Unit:mm

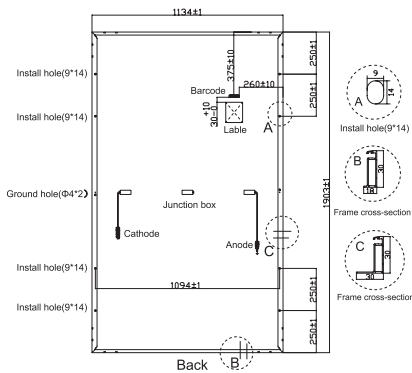
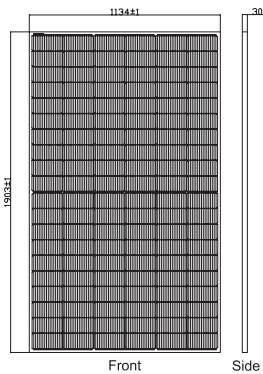

MECHANICAL CHARACTERISTICS

Cell Type (mm)	182*91 N-Type Mono
No. Of Cells	120(12*10)
Module Dimensions(mm)	1903*1134*30
Weight	23.80kg
Monofacial Glass Front Glass(mm)	3.2mm AR Coating Tempered Glass
Frame	Anodized Aluminium Alloy(Silver)
Junction Box	IP68,1500VDC, 3 Schottky Bypass Diodes
Cables	4.0mm ² ,Positive(+)350mm,Negative(-)350mm
Connector	IP68
Snow Load/Wind Load	5400Pa/2400Pa
Class Of Safety Protection	Class II
IEC Component Fire Rating	Class C

OPERATING PARAMETERS

Maximum System Voltage	1500V
Operational Temp	-40~+85 °C
Max Series Fuse Rating	25A
Nominal Module Operating Temp (NMOT)	45±2°C

TEMP COEFFICIENT

Temp Coefficient Of Pmax	-0.300%/°C
Temp Coefficient Of Voc	-0.260%/°C
Temp Coefficient Of Isc	+0.047%/°C

PACKING STANDARD 40FT (HQ)

Number Of Modules Per Pallet	37
Number Of Pallets Per Container	24
Number Of Modules Per Container	888

505W NEW
DUAL GLASS **TrinaSolar**
N type i-TOPCon MODULE

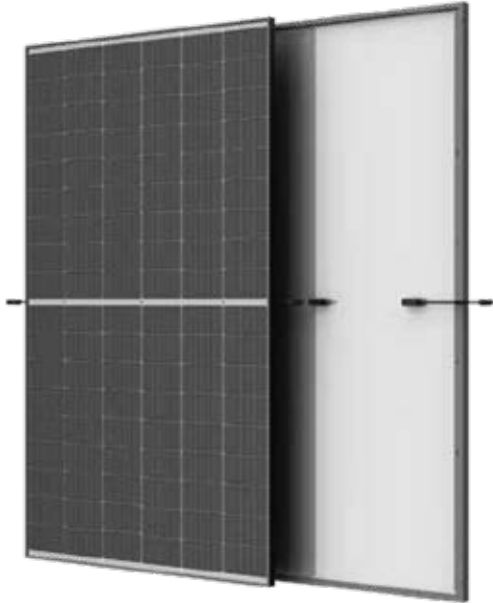

Model No:	TSM-505-NEG18R.28
SKU Code:	12640
EAN Code:	3800170251922
Modules per box:	36 pieces
Modules per 40' container:	864 pieces

ELECTRICAL DATA (STC)

Peak Power Watts-PMAX (Wp)*	505
Power Selection (W)**	0/+5
Maximum Power Voltage-VMPP (V)	33.5
Maximum Power Current-IMPP (A)	15.09
Open Circuit Voltage-VOC (V)	40.3
Short Circuit Current-ISC (A)	15.89
Module Efficiency m (%)	22.7

ELECTRICAL DATA(NOCT)

Maximum Power-PMAX (Wp)	386
Maximum Power Voltage-VMPP (V)	31.8
Maximum Power Current-IMPP (A)	12.81
Open Circuit Voltage-VOC (V)	38.3
Short Circuit Current-ISC (A)	12.15

DIMENSIONS OF PV MODULE (mm)

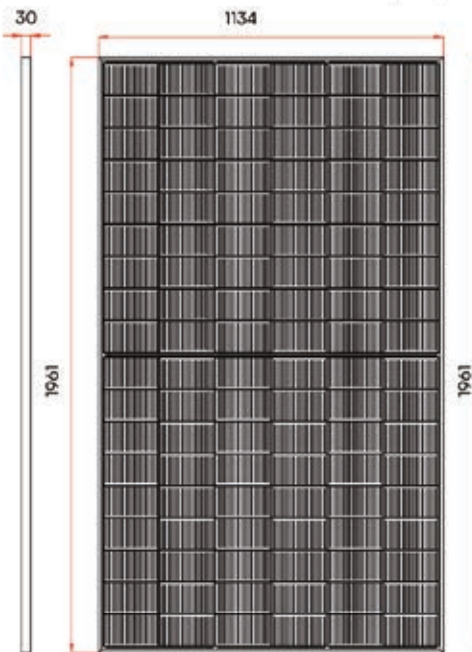

Front View

MECHANICAL CHARACTERISTICS

Solar Cells	Monocrystalline
No. of cells	108 cells
Module Dimensions	1961×1134×30 mm
Weight	23.5 kg
Front Glass	1.6 mm, High Transmission, AR Coated Heat Strengthened Glass
Back Glass	1.6 mm, Heat Strengthened Glass
Frame	30 mm Anodized Aluminium Alloy, Black
J-Box	IP 68 rated, 3 bypass diodes
Connector	TS4 / TS4 Plus / MC4 EVO2*
Cables	Photovoltaic Technology Cable 4.0 mm2
	Landscape: 1300/1300 mm
	Portrait: 280/350 mm*

TEMPERATURE & MAXIMUM RATING

NOCT(Nominal Operating Cell Temperature)	43°C (±2°C)
Temperature Coefficient of PMAX	-0.29%/°C
Temperature Coefficient of VOC	-0.24%/°C
Temperature Coefficient of ISC	0.04%/°C
Operational Temperature	-40 to +85 °C
Maximum System Voltage	1500 V DC (IEC)
Max Series Fuse Rating	30A

510W NEW
DUAL GLASS **TrinaSolar**
N type i-TOPCon MODULE

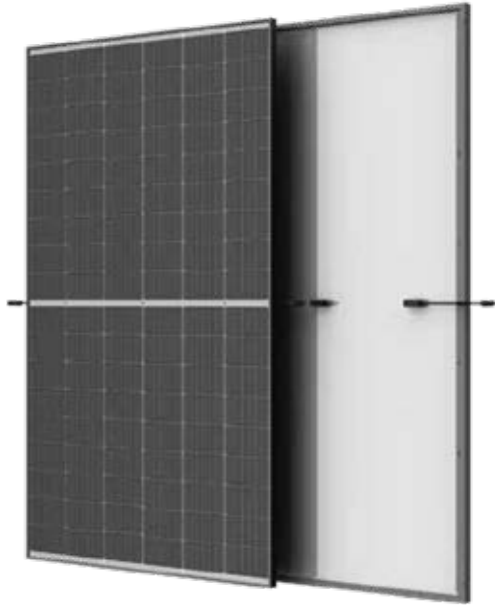

Model No:	TSM-510-NEG18R.28
SKU Code:	12641
EAN Code:	3800170251939
Modules per box:	36 pieces
Modules per 40' container:	864 pieces

ELECTRICAL DATA (STC)

Peak Power Watts-PMAX (Wp)*	510
Power Selection (W)**	0/+5
Maximum Power Voltage-VMPP (V)	33.7
Maximum Power Current-IMPP (A)	15.14
Open Circuit Voltage-VOC (V)	40.6
Short Circuit Current-ISC (A)	15.93
Module Efficiency η (%)	22.9

ELECTRICAL DATA(NOCT)

Maximum Power-PMAX (Wp)	390
Maximum Power Voltage-VMPP (V)	31.9
Maximum Power Current-IMPP (A)	12.21
Open Circuit Voltage-VOC (V)	38.5
Short Circuit Current-ISC (A)	12.84

DIMENSIONS OF PV MODULE (mm)

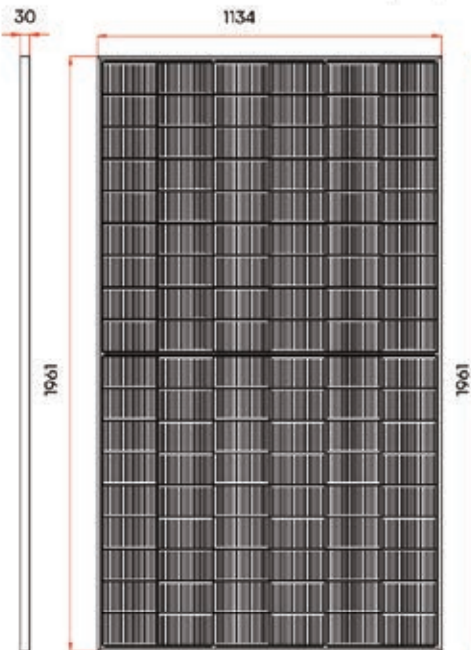

Front View

MECHANICAL CHARACTERISTICS

Solar Cells	Monocrystalline
No. of cells	108 cells
Module Dimensions	1961×1134×30 mm
Weight	23.5 kg
Front Glass	1.6 mm, High Transmission, AR Coated Heat Strengthened Glass
Back Glass	1.6 mm, Heat Strengthened Glass
Frame	30 mm Anodized Aluminium Alloy, Black
J-Box	IP 68 rated, 3 bypass diodes
Connector	TS4 / TS4 Plus / MC4 EVO2*
Cables	Photovoltaic Technology Cable 4.0 mm ²
	Landscape: 1300/1300 mm
	Portrait: 280/350 mm*

TEMPERATURE & MAXIMUM RATING

NOCT(Nominal Operating Cell Temperature)	43°C (±2°C)
Temperature Coefficient of PMAX	-0.29%/°C
Temperature Coefficient of VOC	-0.24%/°C
Temperature Coefficient of ISC	0.04%/°C
Operational Temperature	-40 to +85 °C
Maximum System Voltage	1500 V DC (IEC)
Max Series Fuse Rating	30A

550W

Mono Half Solar Panel

Model No:	VT-11550
SKU Code:	11831
EAN Code:	3800170208636
40HQ container:	20 Pallets/620pcs



ELECTRICAL DATA (STC)

Peak Power(Pmax)	550.00
Maximum Power Voltage(Vmp)	42.10
Maximum Power Current(Imp)	13.06
Open Circuit Voltage(Voc)	50.10±3%
Short Circuit Current(Isc)	14.01±3%
Module Efficiency(%)	21.28

ELECTRICAL DATA(NOCT)

Peak Power(Pmax)	408.9
Maximum Power Voltage(Vmp)	39.09
Maximum Power Current(Imp)	10.46
Open Circuit Voltage(Voc)	46.92±3%
Short Circuit Current(Isc)	11.20±3%

MECHANICAL CHARACTERISTICS

Cell Type	182*91 Mono
No. of Cells	144(12*12)
Dimensions	2279*1134*35mm
Weight	28.40kg
Front Glass	3.2mm high transmission, low iron, tempered glass
Frame	Anodized Aluminium Alloy
Junction box	IP68 3diodes
Output cables	4mm ² cable 35cm(Including MC4 connector)
MaxWind Load/Snow Load	2400Pa/5400Pa

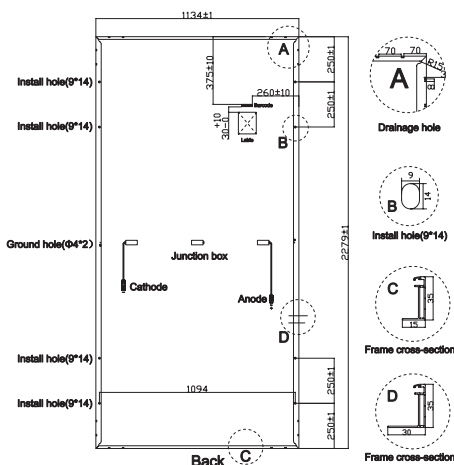
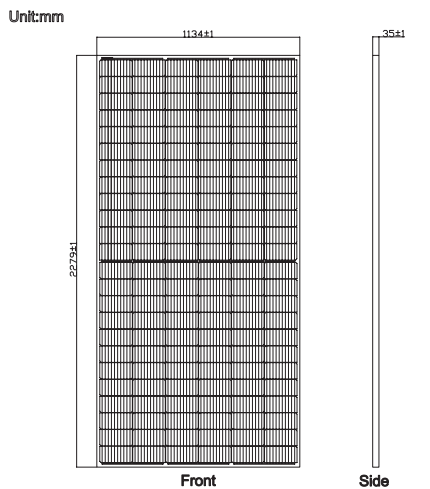

TEMPERATURE & MAXIMUM RATING

Maximum System Voltage(V)	1500 V
Maximum Series Fuse Rating(A)	25 A
Power Tolerance	0~+3 W
Pmax Temperature Coefficient(W/°C)	-0.350 %/°C
Voc Temperature Coefficient(V/°C)	-0.285 %/°C
Isc Temperature Coefficient(A/°C)	+0.045 %/°C
NOCT Nominal Operating Cell Temperature(°C)	45±2 °C
Operating and Storage Temperature(°C)	-40~+85 °C

580W **NEW**

N-Type Monofacial Solar Panel

SKU Code: 12295



ELECTRICAL DATA (STC)

Rated Peak Power-Pmax(Wp)	580.00
Maximum Power Voltage-Vmp(V)	42.37
Maximum Power Current-Imp(A)	13.69
Open Circuit Voltage-Voc(V)	51.02±3%
Short Circuit Current-Isc(A)	14.47±3%
Module Efficiency(%)	22.45

ELECTRICAL DATA (NOCT)

Rated Peak Power-Pmax(Wp)	437.00
Maximum Power Voltage-Vmp(V)	39.77
Maximum Power Current-Imp(A)	10.97
Open Circuit Voltage-Voc(V)	48.46±3%
Short Circuit Current-Isc(A)	11.68±3%

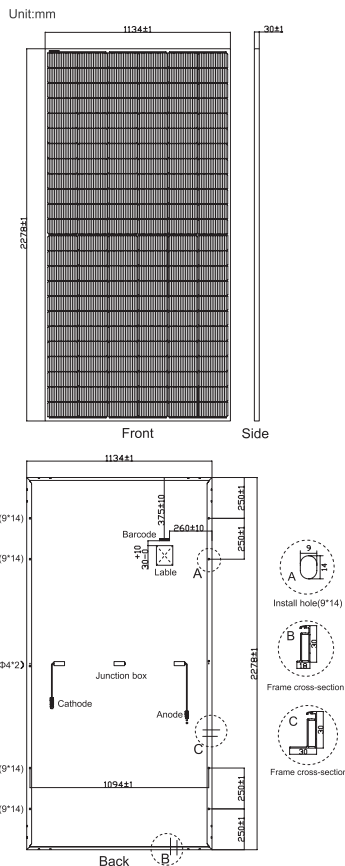

MECHANICAL CHARACTERISTICS

Cell Type (mm)	182*91 N-Type Mono
No. Of Cells	144(12*12)
Module Dimensions(mm)	2278*1134*30
Weight	27.40kg
Monofacial Glass Front Glass(mm)	3.2mm AR Coating Tempered Glass
Frame	Anodized Aluminium Alloy(Silver)
Junction Box	IP68,1500VDC, 3 Schottky Bypass Diodes
Cables	4.0mm ² ,Positive(+)350mm,Negative(-)350mm
Connector	IP68
Snow Load/Wind Load	5400Pa/2400Pa
Class Of Safety Protection	Class II
IEC Component Fire Rating	Class C

OPERATING PARAMETERS

Maximum System Voltage	1500V
Operational Temp	-40~+85 °C
Max Series Fuse Rating	25A
Nominal Module Operating Temp (NMOT)	45±2°C

PACKING STANDARD 40FT (HQ)

Number Of Modules Per Pallet	37
Number Of Pallets Per Container	20
Number Of Modules Per Container	740

TEMP COEFFICIENT

Temp Coefficient Of Pmax	-0.300%/°C
Temp Coefficient Of Voc	-0.260%/°C
Temp Coefficient Of Isc	+0.047%/°C

590W **NEW**

Double Glass Bifacial TOPCon Technology Solar Panel



Model No:	ODA590-36V-MHD
SKU Code:	12271
EAN Code:	3800170227217
20FT container:	5 pallets/185pcs
40FT container	20 pallets/740pcs

ELECTRICAL DATA (STC)

Peak Power(Pmax)	590.00
Maximum Power Voltage(Vmp)	42.67
Maximum Power Current(Imp)	13.83
Open Circuit Voltage(Voc)	51.41±3%
Short Circuit Current(Isc)	14.63±3%
Module Efficiency(%)	22.83

ELECTRICAL DATA (NOCT)

Peak Power(Pmax)	445.00
Maximum Power Voltage(Vmp)	40.03
Maximum Power Current(Imp)	11.12
Open Circuit Voltage(Voc)	48.72±3%
Short Circuit Current(Isc)	11.83±3%

ELECTRICAL DATA(BNPI)

Peak Power(Pmax)	654.00
Maximum Power Voltage(Vmp)	42.67
Maximum Power Current(Imp)	15.33
Open Circuit Voltage(Voc)	51.41±3%
Short Circuit Current(Isc)	16.21±3%

MECHANICAL CHARACTERISTICS

Cell Type	182 *91 N Type Bifacial Mono
No. of cells	144(12 * 12)
Dimensions	2278 * 1134 *30mm
weight	32.00kg
Front Glass	2.0mm AR coating tempered glass
Back Glass	2.0mm Glazed Glass
Frame	Anodized Aluminium Alloy
Junction box	IP68 3diodes
Output cables	4mm2 cable 35cm (Including Mc4 connector)
Maxwind Load/snow Load	2400pa/5400pa
Class of Safety Protection	Class II
IEC Component Fire Rating	Class C

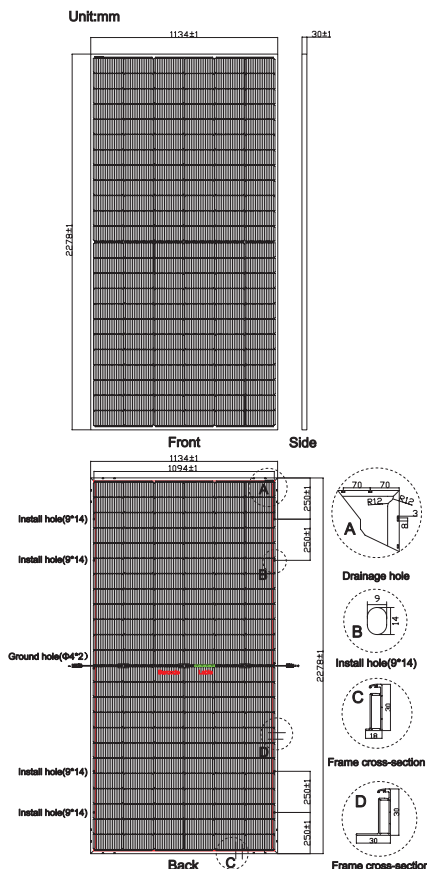

TEMPERATURE & MAXIMUM RATING

Maximum System Voltage (V)	1500
Maximum Series Fuse Rating (A)	30
Power Tolerance	0~+3
Pmax Temperature Coefficient (W/°C)	-0.290 %
Voc Temperature Coefficient (V/°C)	-0.250 %
Isc Temperature Coefficient (A/°C)	+0.041 %
NOCT Nominal Operating Cell Temperature (°C)	45±2
Operating and Storage Temperature (°C)	-40~+85

610W **NEW**

BIFACIAL DUAL GLASS MONOCRYSTALLINE MODULE



Model No:	TSM-NEG19RC.20
SKU Code:	12634
EAN Code:	3800170251694

ELECTRICAL DATA

Testing Condition	STC	NOCT	BNPI
Peak Power Watts-PMAX(Wp)*	610	465	676
Power Selection (W)**	0 ~ +5	0 ~ +5	0 ~ +5
Maximum Power Voltage-VMPP (V)	39.79	37.60	39.79
Maximum Power Current-IMPP (A)	15.33	12.38	17.00
Open Circuit Voltage-VOC (V)	48.09	45.70	48.09
Short Circuit Current SC (A)	16.14	13.00	17.88
Module Efficiency η (%)	22.6	22.6	22.6

ELECTRICAL CHARACTERISTICS WITH DIFFERENT POWER BIN

	5%	10%
Backside Power Gain		
Peak Power Watts-PMAX(Wp)	641	671
Maximum Power Voltage-VMPP (V)	39.79	39.79
Maximum Power Current-IMPP (A)	16.10	16.86
Open Circuit Voltage-VOC (V)	48.09	48.09
Short Circuit Current-ISC (A)	16.95	17.75

MECHANICAL CHARACTERISTICS

Solar Cells	N-type i-TOPCon Monocrystalline
No. of cells	132 cells
Module Dimensions	2382×1134×30 mm (93.78×44.65×1.18 inches)
Weight	33.0 kg (72.8 lb)
Front Glass	2.0 mm (0.08 inches), AR Coating Heat Strengthened Glass
Back Glass	2.0 mm (0.08 inches), Heat Strengthened Glass (White Coating)
Frame	30mm(1.18 inches), Anodized Aluminium Alloy
J-Box	IP 68 rated
Connector	MC4 EVO2 / TS4 Plus / TS4*
Packaging	Modules per box: 36 pieces, Modules per 40' container: 720 pieces
Cables	Photovoltaic Technology: Cable 4.0mm ² (0.006 inches ²), Portrait: 350/280 mm(13.78/11.02 inches)

NOCT (Nominal Operating Cell Temperature)	43°C! (± 2 °C)
Temperature Coefficient of PMAX	- 0.29% /°C
Temperature Coefficient of VOC	- 0.24% /°C
Temperature Coefficient of ISC	0.04% /°C



PV CABLES

	50M ROLL	100M ROLL	500M ROLL
4mm ² Red	SKU : 11821	SKU : 11418	SKU : 11807
4mm ² Black	SKU : 11822	SKU : 11414	SKU : 11805
6mm ² Red	SKU : 11829	SKU : 11419	SKU : 11808
6mm ² Black	SKU : 11830	SKU : 11415	SKU : 11806

4mm²

Conductor
Size
Stranding
Diameter
Primary Insulation
Minimum Average Thickness
Secondary Insulation
Minimum Average Thickness
Outer Diameter

Stranded tinned copper
4mm ²
56/0.285±0.01mm
2.4mm
XLPE
0.7mm
XLPE
0.8mm
5.5±0.15mm

6mm²

Stranded tinned copper
6mm ²
84/0.285±0.01mm
3.0mm
XLPE
0.7mm
XLPE
0.8mm
6.1±0.2mm

50M ROLL



100M ROLL



500M ROLL



Solar DC String Box

2 Strings Input 2 Strings Output DC

SKU Code: [11951](#)



GENERAL DATA

Input	2 strings
Output	2 strings
Maximum Voltage	1000V
Max DC Short Circuit Current Per Input (Isc)	16A (Changeable)
Maximum Current Output	16A

PV SURGE PROTECTOR

Max Operation Voltage (Ucpv)	1000V
Standard Compliance with	IEC/EN 61643-31
Maximum Discharge Current	40kA
Certification	TUV, CE

ENCLOSURE

Material Type	Polycarbonate/ABS
Degree of Protection	IP65
Degree of Resistance to Impacts	IK08
Dimension (WxHxD)	273 x 365 x 118mm
Cable input Entry	PG09 Cable Gland, 2.5-16mm ²
Output Cable Gland	PG21 2.5-16mm ²

ENVIRONMENT

Operating Temperature	-20 °C to + 60 °C
Humidity	99%
Altitude	2000M
Installation	Wall Mounting

DC CIRCUIT BREAKERS

Rated Insulation Voltage (Ui)	1000V
Rated Current (Ie)	16A (Changeable)
Category	DC-Breaker
Standard Compliance with	IEC/EN 60947-2
Certification	CE

DC FUSE HOLDER

Thermoplastic	Yes
Standard Compliance with	IEC 60269-6
Rated Working Voltage	1000V
Fuse Link	10x38mm, 16A (Changeable)
Certification	CE

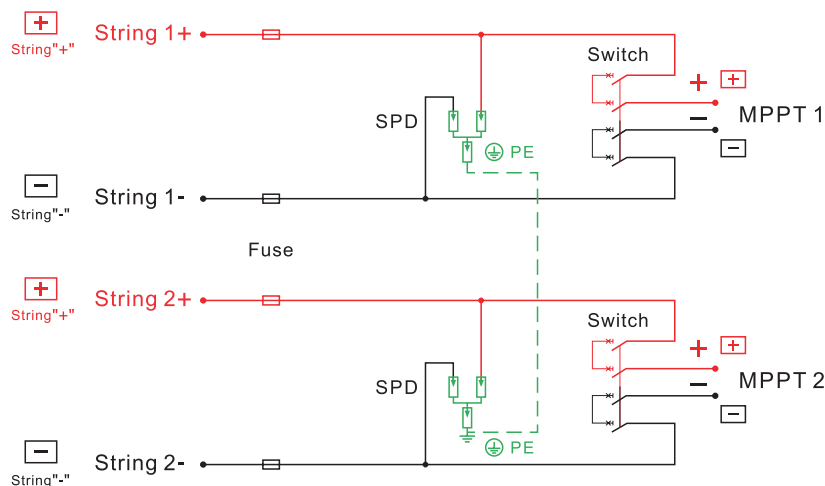

Solar DC String Box

3 Strings Input 3 Strings Output DC

SKU Code: [11952](#)



GENERAL DATA

Input	3 strings
Output	3 strings
Maximum Voltage	1000V
Max DC Short Circuit Current Per Input (Isc)	16A (Changeable)
Maximum Current Output	16A

PV SURGE PROTECTOR

Max Operation Voltage (Ucpv)	1000V
Standard Compliance with	IEC/EN 61643-31
Maximum Discharge Current	40kA
Certification	TUV, CE

ENCLOSURE

Material Type	Polycarbonate/ABS
Degree of Protection	IP65
Degree of Resistance to Impacts	IK08
Dimension (WxHxD)	38 1 x 365 x 118mm
Cable input Entry	PG09 Cable Gland, 2.5-16mm²
Output Cable Gland	PG21 2.5-16mm²

ENVIRONMENT

Operating Temperature	-20 °C to + 60 °C
Humidity	99%
Altitude	2000M
Installation	Wall Mounting

DC CIRCUIT BREAKERS

Rated Insulation Voltage (Ui)	1000V
Rated Current (Ie)	16A (Changeable)
Category	DC-Breaker
Standard Compliance with	IEC/EN 60947-2
Certification	CE

DC FUSE HOLDER

Thermoplastic	Yes
Standard Compliance with	IEC 60269-6
Rated Working Voltage	1000V
Fuse Link	10x38mm, 16A (Changeable)
Certification	CE

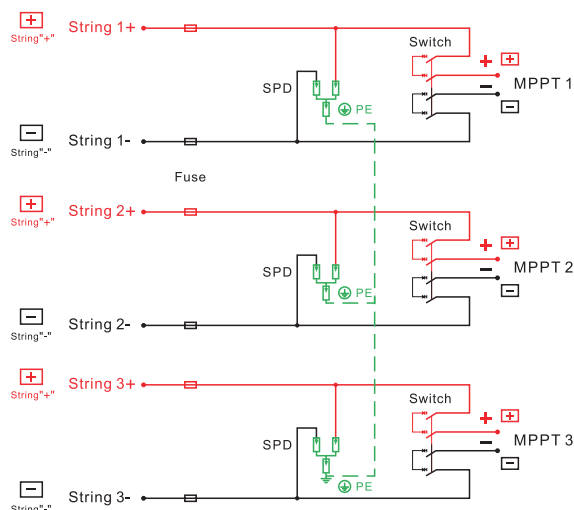

END CLAMP 35MM
SKU: 11388



MIDDLE CLAMP 35MM SKU: 11389



SILVER RAIL 1.2 METER SKU: 11390
2 METERS SKU: 11538



ROOFTOP HOOK-01 SKU: 11391



L FEET GROUP
SKU: 11583



STEEL HORSE-SHAPED KLIPLOCK01 SET
SKU: 11584



STEEL HORSE-SHAPED KLIPLOCK02 SET
SKU: 11585



TT-NUT
SKU: 11392



SPLICE FOR RAIL
SKU: 11394



GROUNDING PLATE
SKU: 11395



ADJUSTABLE FRONT LEG
SKU: 11417



ADJUSTABLE REAR LEG
(10°-15°) SKU: 11385
(15°-30°) SKU: 11386



PV CABLE CONNECTOR-MC4
SKU: 11413



TRIANGLE SUPPORT-1700
SKU: 11387



PV6 CABLE WITH MC4 CONNECTORS 2 END FOR SOLAR PANEL CONNECTION
1 METER SKU: 11570
2.5 METERS SKU: 11416



WIFI DONGLE FOR INVERTERS
SKU: 11528 SKU: 11378



STORAGE BATTERY RACK MAX 5 LAYERS
SKU 11556
Size: 558*500*160mm
Adapting Battery-
VT48100E-P2



STORAGE BATTERY RACK MAX 3 LAYERS
SKU 11557
Size: 598*589*260mm
Adapting Battery-
VT48200B





SINGLE PHASE SMART METER

SKU: 11545

Nominal voltage	220V, 230, 240V
Current	5(80) A
Reference frequency	50Hz or 60Hz
Accuracy	Class 1.0
Operating range	0.85Un ~ 1.15Un
Power consumption	Voltage loop: 1W/5VA; Current loop: 2VA



THREE PHASE SMART METER

SKU: 11546

Nominal voltage	3x220~240/380~415V; 3x120~138/208~240V
Current	Direct access: 5(80)A; Mutual access: 1.5(6)A
Reference frequency	50Hz or 60Hz
Accuracy	Class 1.0 for 5(80)A; Class 0.5 for 1.5(6)A
Operating range	0.85Un ~ 1.15Un
Power consumption	1W/8VA

The logo for V-TAC, featuring the letters 'V-TAC' in a bold, green, sans-serif font. The 'V' and 'T' are connected, and the 'A' is a simple triangle. The 'C' is a simple curve. The background is a dark space with a glowing green planet on the right side.

V-TAC

Meaningful Innovation.

TO MAKE THE WORLD
A BRIGHTER PLACE
THROUGH MEANINGFUL
INNOVATION.

Everything we do is strengthened by our purpose to make this world a brighter place, by providing high-quality, efficient, and sustainable products to our customers.

Our idea of a brighter world is where we enable people to make their lives more comfortable and safe while building a sustainable future.

MOVING TOWARDS
SUSTAINABILITY.



V-TAC

Meaningful Innovation.

OUR VISION & MISSION

THE BIGGER PICTURE VISION

To become a global leader in providing the most efficient and sustainable products.

THE DRIVING FORCE MISSION

Harness the power of meaningful innovation into providing absolute value to our customers and the planet.

V-TAC

Meaningful Innovation.

TOWARDS A BRIGHTER FUTURE



RoHS

CEI 0-21

CERTIFICATE

Sofia Office

V-TAC Europe Ltd
41, bul. Rozhen
1271 Sofia
Bulgaria
www.v-tac.eu
office@v-tac.eu

UK Office

V-TAC House, Kelpatrick Road,
Slough, Berkshire, SL1 6BW, UK.
www.v-tac.co.uk
info@v-tac.co.uk

Hungary Office

Népfürdő utca 13. | H-1138
Budapest, Ungarn

Romania Office

Bulevardul Unirii, numărul 33
(vis-a-vis de Institutul Bancar Român),
București

Poland Office

V-TAC POLAND sp. z o.o.
Ul. Obornicka 330
60-689 Poznań

Middle East Office

Unit# 407/8/9 Jumeirah Bay Towers,
Plot# X3, JLT, P.O. Box 45244, Dubai

V-TAC West Europe

Ground Floor, 71 Lower Baggot
Street, Dublin O2, Ireland
D02 P593

GLOBAL YET LOCAL

